

Essays on Asymmetry and Tails: Different Approaches

Sofia Cazzaniga

6 December 2013

A dissertation submitted for the degree of
Ph.D. in Finance

Members of the commission:

Professor Francesco Franzoni (thesis advisor, USI)

Professor Pasquale Della Corte (Imperial College Business School, London)

Professor Alberto Plazzi (USI)

Professor Giovanni Barone-Adesi (USI)

Faculty of Economics
Università della Svizzera Italiana

Introduction

The limits of the Gaussian distribution for modeling returns of financial data have been extensively documented by researchers (see for instance Fama (1965), Cont (2001) and more recently Gabaix (2009) for a comprehensive review). In a Gaussian setting, only the expected value and standard deviation (asymmetric deviations) matter for an exhaustive description of returns and for risk measurement. In case of departures from normality, such as in skewed and leptokurtic processes, we need to introduce measures of asymmetry and we need to investigate the role of events far away from the mean, i.e. in the tails. An accurate modeling of individual series and portfolios returns is of primary importance for predictability, asset allocation and derivative pricing purposes.

Understanding and reproducing the properties of low probability events, of moments beyond the mean and the variance, thus capturing and investigating the role of asymmetry and leptokurtosis, have been the topics of my research during my years of PhD at the institute of Finance at USI.

My thesis consists of three essays¹.

1. **“Multiplicative Noise, Fast Convolution, and Pricing”**,
Quantitative Finance, 14(3), (2014), 481-494.
In collaboration with Giacomo Borinetti, Scuola Normale Superiore di Pisa, Italy.
2. **“Downside Risk in Currency Markets, Do Skewness and Tails Matter?”**, working paper.
3. **“Country-Specific Characteristics, Equity Capital Flows and Carry Trade”**, working paper.

¹Notice that the order the essays are presented is mere temporal.

1. Multiplicative Noise, Fast Convolution, and Pricing

This article deals with numerical characterization of non-normal stochastic processes, that describe financial assets returns, and with their application to financial modeling. Realistic stochastic processes used for modeling the evolution of return/volatility series do not allow, in general, for an analytical representation of the conditional probability density function of returns. Therefore, usually, time consuming lattice/Monte-Carlo simulation methods have to be used. In this article we detail the application of a Fast Convolution Algorithm (FCA) (Eydeland (1994)). The algorithm provides a numerical solution to the problem of characterizing conditional probability density functions at arbitrary time. Indeed by exploiting the repeated application of the Chapman-Kolmogorov equation, we can reformulate the problem in terms of Fourier and anti-Fourier transforms (then easily performed via fast Fourier transform -FFT-algorithm) of the initial state vector. FCA methodology is therefore prone to several financial applications, in particular to the computation of high dimensional integrals in the context of option pricing. This is the application we choose to detail thoroughly. Because of their ability in reproducing statistical features of financial return time series, such as thickness of the tails and scaling properties, we choose, as sample processes, the family of quadratic diffusion (Bormetti and Delpini (2010), Delpini and Bormetti (2011)) and the family of piecewise linear diffusion (McCauley, and Gunaratne (2003), Alejandro-Quiñones et al. (2006)), both belonging to the big family of multiplicative noise processes. In numerical sections we document considerable gains in efficiency, a reduction in complexity and execution time of the FCA algorithm with respect to Monte Carlo (MC) inspired techniques.

2. Downside Risk in Currency Markets, Do Skewness and Tails Matter? This working paper investigates the role of asymmetry and of low probability exchange rates movements on the profitability of foreign currencies investment strategies. To these purposes, a factor ($SKEW^{HML}$) tracking the aggregate downside risk in

FX markets and exploiting the asymmetries in exchange rate returns is introduced. Using standard asset pricing tests, I find that this skewness factor plays a statistically and economically significant role, explaining the cross section of currencies expected excess returns. Therefore it is capable of providing at least partially, a rational explanation to the high profitability of currency carry trade (CT) strategies. High values of $SKEW_M^{HML}$ identify bad states of downside risk, owing to episodes of high interest rate currencies depreciation and the poor carry trade performance. Low interest rate currencies positively co-move with skewness factor, thus they play the role of a hedge by offering high returns in bad states for the skewness, low returns in good states. On the contrary, high interest rate currencies are negatively correlated with the skewness factor, thus they yield big abnormally positive profits to a US investor long foreign currencies in low skewness realizations states (good states) and big losses when the skewness factor assumes high and positive values. Therefore a carry trade investor, having a long position in high and a short position in low interest rate currencies, is extremely exposed to the downside risk mimicked by $SKEW_M^{HML}$. Importantly, the skewness factor keeps significance after accounting for the effect of volatility. Finally by means of Extreme Value Theory techniques, we construct a factor, which turns out to be related to $SKEW_M^{HML}$, tracking the downside risk of deep-into-the-tails return series observations, and we show that it is priced in the cross section of carry trade excess returns. We therefore confirm that asymmetry and fat tails of exchange rate return distribution (we measured either with $SKEW_M^{HML}$ or with the Tail factor) are among the driving sources of carry trade time-varying risk premium, besides volatility.

This working paper reconciles two main strands of literature. The first, concerned with currency return anomalies, investigates priced risk factors that can explain the high profitability of currency strategies (see Lustig et al. (2011) PCA analysis and HML_{FX} factor, Menkhoff et al. (2012) global volatility factor, Mueller et al. (2012) correlation risk factor, Verdelhan (2012) dollar factor). The second studies down-

side risk and crashes in currency markets, known to exhibit dramatic movements even without fundamental news announcements (Brunnermeier Nagel and Pedersen (2008), Fahri and Gabaix (2011), Fahri et al. (2009), Jurek (2008), Burnside et al. (2011)).

We use data on spot and 1-month-forward exchange rates of the currencies of 47 different countries versus the USD. The data are downloaded from Datastream and cover the sample period from January 1985 to March 2011 (monthly frequency, end of month series).

3. Country-Specific Characteristics, Equity Capital Flows and Carry Trade In this paper, we study country-specific characteristics and we assess their impact on currency excess returns. We introduce a measure of country specific co-dependence between carry trade excess returns and the equity market of the target country in bad states of the local economy and we call it “downside beta”. With this measure we can identify countries whose excess carry trade returns depend differently and with different strength from the performance of their respective local equity market. Moreover, by means of portfolio sorting approach, we asses that, besides standard risk factors for the currency market, the country specific characteristics we are investigating affect the performance of currency strategies. We indeed find that the expected excess return decrease monotonically with the level of co-dependence. We attribute our findings to capital movements of international equity investors who react to local equity market conditions. Equity investors move their capital because of portfolio rebalancing issues or in order to unwind positions in markets that are experiencing negative returns. Not only our results are in agreement with previous papers that investigate the links between currency and stock market (Hau and Rey (2006), Francis et al. (2006) and Chaban (2009)), but also they enrich this literature which is, to our knowledge, very little. Finally extreme value theory techniques are employed in order to verify whether the results are driven by crashes of the equity

markets, or if they are indeed truly reflecting downside aversion to bad states of the local markets. No effect of country crashes is found in the data.

Overall our results underly the importance of downside measure of co-movement between the currency and the equity market. Indeed tracking the dependence measure of carry trade from equity excess returns can be very useful as it might be exploited for real-time portfolio selection, Sharpe ratio targeting, and many other applications.

This paper is related to different strands of literature: the one dealing with empirical microstructure issues in the forex market (Evans and Lyons (2002), Lyons (2001)), the one dealing with downside aversion and downside risk (Roy (1952), Brunnermeier and Pedersen (2009), Ang et al. (2006), Maggiori et al. (2012), Dobrynskaya (2012)), and the one dealing with the role of extreme observations in return series and with extreme value theory applications to finance (Poon et al. (2004)).

We use daily data of the equity indexes (Datastream Global Equity Indexes) of 42 different countries and of spot and 1-month-forward exchange rates of their respective currencies versus the USD. All data are downloaded from Datastream. The sample period starts in January 2 1986 and ends in December 30 2011.

Contents

1	Multiplicative noise, fast convolution, and pricing	10
1.1	Introduction	11
1.2	Stochastic processes with multiplicative noise	13
1.3	Fast convolution algorithm	16
1.4	Fast convolution at work: numerical result	19
1.5	Financial applications	23
1.6	A piecewise diffusion under risk-neutrality: Plain Vanilla pricing	23
1.7	Exotic options: the geometric Asian case	25
1.8	The Vellekoop-Nieuwenhuis-Borland model	27
1.9	Numerical results	30
1.10	Conclusion	31
2	Downside Risk in Currency Markets, Do Skewness and Tails Matter?	42
2.1	Introduction	43
2.2	Currency data and Portfolios Formation	50
2.3	Risk Factors	52
2.4	Empirical Evidences	53
2.5	Empirical Analysis	58
2.6	Robustness Check	63
2.7	Power Laws and Carry Trade	65
2.8	Tail Index Risk Factor	66
2.9	Conclusion	69
	Appendices	95

A	Extreme Value Theory	95
3	Country-Specific Characteristics, Equity Capital Flows and Carry Trade	98
3.1	Introduction	99
3.2	Data	104
3.3	Methodology	105
3.4	Downside-beta Portfolios	106
3.5	Downside Country Specific Expected Returns	107
3.6	Country-Specific Downside versus Global Downside	110
3.7	Flow Tracking Variable	112
3.8	Tail Dependence	113
3.9	Estimation of left tail dependence measures $\bar{\chi}$ and χ	116
3.10	Robustness	117
3.11	Conclusion	118
	Appendices	138
B	Tail Index and Hill Estimator	138

1 Multiplicative noise, fast convolution, and pricing

Sofia Cazzaniga

University of Lugano and Swiss Finance Institute

Giacomo Borretti

Scuola Normale Superiore, Pisa

Quantitative Finance, 14(3), (2014), 481-494

abstract

In this work we detail the application of a fast convolution algorithm to compute high dimensional integrals in the context of multiplicative noise stochastic processes. The algorithm provides a numerical solution to the problem of characterizing conditional probability density functions at arbitrary time, and we apply it successfully to quadratic and piecewise linear diffusion processes. The ability to reproduce statistical features of financial return time series, such as thickness of the tails and scaling properties, makes this processes appealing for option pricing. Since exact analytical results are lacking, we exploit the fast convolution as a numerical method alternative to the Monte Carlo simulation both in the objective and risk neutral settings. In numerical sections we document how fast convolution outperforms Monte Carlo both in speed and efficiency terms.

Keywords: Computational Finance, Stochastic Processes, Non-Gaussian Option Pricing, Numerical Methods for Option Pricing

*The authors acknowledge the support of the Scuola Normale Superiore Grant ‘Giovani Ricercatori (2011/2012)’ and Prof. Giovanni Barone-Adesi for his precious advice.

1.1 Introduction

Two of the basic problems computational finance has to deal with are the choice of the optimal model driving the stochastic evolution of financial variables and, once a good candidate has been identified, the search of a reliable way for its fast and accurate simulation. The former issue has been widely investigated both by econometricians, mathematicians, and physicists, as demonstrated by the increasing literature on this topic, see for example Campbell *et al.* (1997), Mandelbrot (1997), Mantegna and Stanley (2004), Bouchaud and Potters (2003), McCauley (2004). Tracing back to the work of Mandelbrot (1963) and the analysis in Fama (1965), empirical studies have shown that financial time series exhibit features departing from the Gaussian assumption. In Cont (2001) a detailed review of the stylized empirical facts emerging in various type of financial markets is presented and discussed. These findings are nowadays accepted as universal evidence, shared among different markets in different periods. From Mandelbrot's earlier results regarding cotton prices or the thick tailed nature of the Dow Jones Industrial Average recognized by Fama, very heterogeneous models have been proposed in order to reproduce the degree of asymmetry and the excess of kurtosis of the empirical distributions. Approaches directly developing from distributional assumptions include the truncated Lévy model discussed by Mantegna and Stanley (2004), and those employing generalized Student- t and exponential distributions, see Bouchaud and Potters (2003); McCauley and Gunaratne (2003). Different mechanisms that also capture the observed non trivial structure of higher order correlation functions model the stochastic nature of the return volatility. Continuous time approaches have been extensively analyzed and range from the fractional Brownian motion, Mandelbrot (1997), to stochastic volatility models, for a review we suggest Fouque *et al.* (2000). Discrete time models include AutoRegressive Conditional Heteroskedastic (ARCH) and Generalized ARCH processes, Bollerslev (1986); Engle (1982), and multifractal models, Borland *et al.* (2005), the latter being inspired by cascades originally introduced by Kolmogorov in the context of turbulent flows. Turbulent velocity flows have also led to a series of empirical works testing and strongly relying on the Markovian nature of foreign exchange returns, Friedrich *et al.* (2000); Ghashghaie *et al.* (1996). The macroscopic description of the ob-

served phenomena is provided in terms of a Fokker-Planck (FP) equation with linear drift and quadratic diffusion coefficients. Processes leading to an equation with the same structure characterize several physical systems, as reviewed by Bormetti and Delpini (2010). Also the statistical feedback mechanism proposed in Borland (2002a,b, 2007) can be recast in terms of non linear diffusion, as originally remarked by McCauley *et al.* (2007a), who also pointed out potential problems arising when computing expectations under power law tailed distributions. Even though these drawbacks have been later amended in Vellekoop and Nieuwenhuis (2007), McCauley *et al.* (2007b) propose switching to exponential tailed PDFs. In particular, they develop a general approach to generate a Markovian process obeying scaling relations starting from a driftless stochastic differential equation (SDE). In the current paper we focus on the numerical characterization of these latter processes, of the above mentioned quadratic diffusion processes, and on applications to financial modeling. In this respect, especially for pricing purposes, i.e. to evaluate expectations of future pay-offs, we need to reconstruct the conditional probability density function (PDF) describing the stochastic dynamics. Yet a closed form expression for the density is rarely available. For this reason several numerical procedures have been developed and have become common practice, e.g. binomial and multinomial lattice algorithms, Monte Carlo (MC) simulation, and partial differential equation solvers (for a review see Brandimarte (2006)). We decide to investigate and widely exploit the fast convolution algorithm (FCA) introduced in Eydeland (1994). The algorithm applies to Markovian stochastic processes: the repeated application of the Chapman-Kolmogorov equation, and a clever problem re-formulation allows us to rewrite functional integrals in terms of Fourier and inverse Fourier transform of the state vector. Performing these operations via a fast Fourier transform (FFT) algorithm, numerical efficiency is achieved and computational complexity is notably reduced. It is interesting to note that some of the key ingredients of the approach we are going to detail have been also discussed in Chaudhary (2007), where a flexible numerical technique to price American options is presented.

The structure of the paper is as follows. After introducing stochastic models we have chosen to investigate, we detail step by step the FCA; in paragraph 1.4 we test its numerical

performance against the standard MC approach for different specification of models and parameter values. Section 1.5 is dedicated to financial applications to option pricing. In 1.6 we derive the risk neutral measure for the piecewise diffusion process of McCauley and Gunaratne (2003), and the exact formula for Plain Vanilla pricing. We then consider geometric Asian options by thoroughly developing the two dimensional setting required by fast convolution, see paragraph 1.7. We exploit the formal analogy between the latter case and the framework discussed by Vellekoop and Nieuwenhuis (2007) and Borland (2002a,b, 2007) to price Plain Vanilla options in paragraph 1.8, and in the final part we collect numerical distributions and implied volatility surfaces proving the reliability of FCA. We draw relevant conclusions and possible perspectives in section 1.10.

1.2 Stochastic processes with multiplicative noise

The multiplicative stochastic processes we investigate in this work correspond to the classes of quadratic diffusion described in Bormetti and Delpini (2010); Delpini and Bormetti (2010), and of piecewise linear diffusion introduced in McCauley and Gunaratne (2003), later rediscussed by Alejandro-Quiñones *et al.* (2006) in a slightly different context.

As far as quadratic diffusion dynamics is concerned, we choose the following stochastic partial differential specification

$$dX_t = \frac{aX_t + b}{g(t)} dt + \sqrt{\frac{cX_t^2 + fX_t + e(t)}{g(t)}} dW_t, \quad (1)$$

with $X_{t_0} = 0$ initial time condition; dW_t is the standard Brownian increment, $1/g(t)$ and $e(t)$ are non-negative smooth functions for $t \geq t_0$. We fix $c > 0$, and, in order for the micro-dynamics to be well-defined, we require $D^2 \doteq 4c e(t) - f^2 \geq 0$: under our constraint the square root argument is non negative, and this guarantees X_t to be a real valued process. Several are the possible parametric forms we could have chosen in order to study quadratic diffusion processes, yet we decide to follow Bormetti and Delpini (2010), where equation 1 has been extensively analyzed, as it reconciles both a high degree of generality and clarity, besides being parsimonious. Alternatively, it can be cast in a Langevin equation whose damping coefficient has a stochastic nature, Biró and Jakovác (2005). In Bormetti and

Delpini (2010) equation (1) has been shown to govern the dynamics of a variety of complex phenomena both in the field of natural science and in economics and finance: turbulent velocity flows, Friedrich and Peinke (1997), power law spectra in e^+e^- , $p\bar{p}$ and heavy ions collisions, Wilk and Włodarczyk (2000), anomalous diffusion phenomena, Borland (1998), non stationary scaling Markov processes, McCauley *et al.* (2007a). Moreover, the same dynamics have been shown to describe heartbeat interval fluctuations, foreign exchange markets, Ghashghaie *et al.* (1996); Ghasemi *et al.* (2006), option markets, Borland (2002a,b, 2007), and the statistical features of medium-term log returns in a market with both fundamental and technical traders, Shaw and Schofield (2012). The explicit analytical characterization of the PDF associated to equation (1) has been carried out only for the steady state, while Bormetti and Delpini (2010) provide a closed form characterization of these processes in terms of the moments at all times and orders, and show that the choice of $g(t)$ is crucial for the understanding of the dynamics of the moments themselves. For instance, when $e(t) = e$ is constant, it is possible to characterize analytically the time evolution of the process X_t , and its convergence to the stationary state. If a is non negative or if e is time dependent, X_t lacks stationarity; however, in the final section of this paper we will discuss an application of this latter case to the context of financial option pricing, tracing back to Borland (2002a,b, 2007), and later revised by Vellekoop and Nieuwenhuis (2007).

The quadratic diffusion process (1) can be formally manipulated to reduce it in a more convenient form by means of the Lamperti transform, as we will see in Section 1.3. Here, we slightly simplify it, introducing a new time variable $\tau(t) = \int_{t_0}^t ds/g(s)$, which we will refer to as the integral time. In this new setting the process X_τ is described by the following dynamics

$$dX_\tau = (aX_\tau + b)d\tau + \sqrt{cX_\tau^2 + fX_\tau + \tilde{e}(\tau)}dW_\tau, \quad (2)$$

with $X_0 = 0$, a, b, c, f constant and $\tilde{e}(\tau) = e(t(\tau))^2$.

We now turn our attention to the second class of multiplicative noise we consider, namely piecewise linear diffusions. Following McCauley *et al.* (2007a) and Alejandro-

²By virtue of the properties of g , τ is a monotonously increasing function of t , implying the well-definiteness of the inverse function $t(\tau)$.

Quiñones *et al.* (2006), this is a class of Markov processes generated locally by the driftless SDE

$$dX_t = \sigma \sqrt{t^{2H-1} \left(1 + \varepsilon \frac{|X_t|}{t^H}\right)} dW_t, \quad \text{with } X_0 = 0, \quad (3)$$

parametric in $H > 0$. This class is extremely interesting from a theoretical viewpoint, as all the processes belonging to it share a main relevant property, called scaling, which relates returns over different sampling intervals. More precisely, a stochastic process X_t is said to scale with Hurst exponent H if the following equality holds in distribution

$$X_t = t^H X_1.$$

Previous relation has several immediate consequences: as can be easily shown, the moments of X_t must obey the relation

$$\mathbb{E}[X_t^n] = c_n t^{nH}, \quad (4)$$

for suitable constants c_n ; moreover, whenever returns are rescaled by a factor t^H , the shape of their distribution must scale according to

$$P(x, t) = \frac{1}{t^H} G(u), \quad (5)$$

where G is the so called scaling function, and $u = x/t^H$. If we now consider the FP equation associated to the SDE (3), we obtain

$$2H(uG(u))' + \sigma^2((1 + \varepsilon|u|)G(u))'' = 0,$$

which admits the following scaling solution

$$P(x, t) = \frac{e^{-\alpha}}{2\sigma^{2\alpha}\varepsilon^\alpha\Gamma[\alpha, \alpha]t^H} \exp\left[-\frac{|x|}{\sigma^2\varepsilon t^H}\right] \left(1 + \varepsilon\frac{|x|}{t^H}\right)^{\alpha-1}, \quad (6)$$

where $\alpha = 1/(\sigma^2\varepsilon^2)$ and $\Gamma[a, z] = \int_z^\infty s^{a-1}e^{-s}ds$. In light of equation 4, to recover the diffusive behaviour of log prices we need to fix $H = 1/2$. The interest in the above density function is manifold, as it is characterized by a simple closed-form expression, from which we can conclude that moments of all orders are finite quantities, and it also naturally captures the excess of kurtosis observed in empirical densities. Moreover, as documented in Baldovin and Stella (2007); Mantegna and Stanley (1995), scaling holds in practice in numerous data

samples, ranging from equity index to FX returns time series. The solution provided by (6) for $H = 1/2$ has to be preferred to a description in terms of Lévy distributions, for which the relation (5) holds through the identification $H = 1/\alpha$, with $0 < \alpha \leq 2$, see Mandelbrot (1963), but for $\alpha \neq 2$ it implies the divergence of the variance, while for $\alpha = 2$ it reduces to the Normal case. McCauley and Gunaratne (2003) and McCauley (2004) derive closed-form option pricing formulae for the density (6); yet they show that consistency between scaling, exponential PDF and martingale option pricing requires the replacement of the Itô correction for X_t under the risk neutral measure with a constant (see McCauley *et al.*, 2007b, section 2). We argue that this approximation is questionable, and we want to perform option pricing without relying on it, therefore we need a numerical methodology whose efficiency and flexibility promise to compensate for the absence of closed-form solution.

1.3 Fast convolution algorithm

In this section we review the fast convolution algorithm proposed in Eydeland (1994).

Let us consider the generic process X_τ , whose dynamics is described by the following general SDE

$$dX_\tau = M_X(X_\tau, \tau)d\tau + D_X(X_\tau, \tau)dW_\tau, \quad X_{\tau=0} = X_0.$$

We start by transforming the process X_τ into one with unitary diffusion coefficient. This is performed via the Lamperti transform (see Iacus, 2008, section 1.11.4), defined as

$$Z_\tau(X_\tau, \tau) = \int_{X_0}^{X_\tau} \frac{d\hat{X}}{D_X(\hat{X}, \tau)}.$$

Under suitable regularity condition Itô Lemma can be applied to $Z_\tau(X_\tau, \tau)$ and its dynamics turns out to be

$$dZ_\tau = M_Z(Z_\tau, \tau)d\tau + dW_\tau, \quad Z_{\tau=0} = 0, \tag{7}$$

with

$$M_Z(Z_\tau, \tau) = \frac{\tilde{M}_X(X(Z_\tau), \tau)}{\tilde{D}_X(X(Z_\tau), \tau)} + \frac{\partial}{\partial \tau} \int_{X_0}^{X(Z_\tau)} \frac{d\hat{X}}{D_X(\hat{X}, \tau)} - \frac{1}{2} \frac{\partial}{\partial X} D_X(X, \tau) \Big|_{X(Z_\tau)}, \tag{8}$$

where \tilde{M}_X is the function $M_X(X_\tau, \tau)$ evaluated at $X(Z_\tau)$, and analogously for \tilde{D}_X . Our aim is to provide an approximate expression for the transition probability density function

$p(z_\tau, \tau | z_0, 0)$ ³. We introduce an equally spaced time grid $0 = \tau^0, \tau^1, \dots, \tau^n = \tau$, with $\tau^i = i\Delta\tau$, in a similar spirit to the path integral approach, see Baaqui (2007); Bormetti *et al.* (2006); Dash (1989); Montagna *et al.* (2002). The repeated use of the Chapman-Kolmogorov equation in this discrete setting allows us to write the transition probability for a generic $\tau > 0$ as a finite high dimensional integral

$$p(z^n | z^0) \simeq \int_{z^n} \int_{z^{n-1}} \dots \int_{z^1} \prod_{i=1}^{n-1} dz^i \pi(z^n | z^{n-1}) \pi(z^{n-1} | z^{n-2}) \dots \pi(z^1 | z^0), \quad (9)$$

where $z^i = z(\tau^i)$, and π is the short time transition PDF that we chose equal to the Normal density

$$\pi(z^{i+1} | z^i) = \frac{1}{\sqrt{2\pi\Delta\tau}} \exp \left[-\frac{(z^{i+1} - z^i - \mathbf{M}_Z(z^i, \tau^i)\Delta\tau)^2}{2\Delta\tau} \right].$$

By means of the new variables $\xi^i \doteq z^i + \mathbf{M}_Z(z^i, \tau^i)\Delta\tau$, the transition becomes symmetric under the exchange of z^{i+1} with ξ^i , i.e. $\tilde{\pi}(z^{i+1} | z^i(\xi^i)) = \tilde{\pi}((z^{i+1} - \xi^i)^2)$. For each one dimensional integration appearing in equation (9), we have

$$p(z^{i+1} | z^0) = \int_{z^i} dz^i \pi(z^{i+1} | z^i) p(z^i | z^0) = \int_{\xi^i} d\xi^i \frac{\partial z^i}{\partial \xi^i} \tilde{\pi}((z^{i+1} - \xi^i)^2) \tilde{p}(z^i(\xi^i) | z^0), \quad (10)$$

where $\tilde{p}(z^i(\xi^i) | z^0)$ is the density $p(z^i | z^0)$ evaluated at $z^i(\xi^i)$, and similarly for $\tilde{\pi}$. If we introduce a numerical integration grid of equally spaced points $z_j^i = \xi_j^i = z_{\min} + j\Delta z$ for all $i = 0, \dots, n$ and $j = 0, \dots, m-1$, where neither z_{\min} nor Δz depend on the time label i , then the PDF $\tilde{\pi}(z_j^{i+1} | \xi_j^i)$ associated to the transition of moving from point ξ_j at time τ^i to point z_j at time τ^{i+1} is a function only of the difference $j' - j$, i.e. $\tilde{\pi}_{j'j} \doteq \tilde{\pi}((j' - j)^2 \Delta z^2)$. The discrete matrix of transition probabilities

$$\tilde{\mathbf{\Pi}} = \begin{bmatrix} \tilde{\pi}_{00} & \tilde{\pi}_{01} & \dots & \tilde{\pi}_{0(m-1)} \\ \tilde{\pi}_{10} & \tilde{\pi}_{11} & \dots & \tilde{\pi}_{1(m-2)} \\ \vdots & \vdots & \ddots & \vdots \\ \tilde{\pi}_{(m-1)0} & \tilde{\pi}_{(m-1)1} & \dots & \tilde{\pi}_{(m-1)(m-1)} \end{bmatrix}, \quad (11)$$

is therefore a symmetric Toeplitz matrix $\tilde{\mathbf{\Pi}}_{ij} = \tilde{\mathbf{\Pi}}_{|i-j|}$, with no dependence on the time

³From now on we will drop the explicit dependence on the time variable τ .

variable. Letting

$$\mathbf{P}^{i+1} = \begin{bmatrix} p(z_0^{i+1}|z^0) \\ p(z_1^{i+1}|z^0) \\ \vdots \\ p(z_{m-1}^{i+1}|z^0) \end{bmatrix}, \mathbf{J}^i = \begin{bmatrix} \frac{\partial z_0^i}{\partial \xi_0^i} & 0 & \dots & 0 \\ 0 & \frac{\partial z_1^i}{\partial \xi_1^i} & \dots & 0 \\ \vdots & \vdots & \ddots & \vdots \\ 0 & 0 & \dots & \frac{\partial z_{m-1}^i}{\partial \xi_{m-1}^i} \end{bmatrix}, \tilde{\mathbf{P}}^i = \begin{bmatrix} \tilde{p}(z_0^i(\xi_0^i)|z^0) \\ \tilde{p}(z_1^i(\xi_1^i)|z^0) \\ \vdots \\ \tilde{p}(z_{m-1}^i(\xi_{m-1}^i)|z^0) \end{bmatrix}, \quad (12)$$

equation (10) can be approximated as

$$\mathbf{P}_j^{i+1} \simeq \Delta z \sum_{k,l=0}^{m-1} \tilde{\Pi}_{jk} \mathbf{J}_{kl}^i \tilde{\mathbf{P}}_l^i.$$

The entries of $\tilde{\mathbf{P}}^i$ are computed by means of the linear interpolation operator

$$\mathbf{I}^i = \frac{1}{\Delta z} \begin{bmatrix} z_1^i - \xi_0^i & \xi_0^i - z_0^i & 0 & \dots & 0 & 0 \\ 0 & z_2^i - \xi_1^i & \xi_1^i - z_1^i & \dots & 0 & 0 \\ \vdots & \vdots & \vdots & \ddots & \vdots & \vdots \\ 0 & 0 & 0 & \dots & z_{m-1}^i - \xi_{m-2}^i & \xi_{m-2}^i - z_{m-2}^i \\ 0 & 0 & 0 & \dots & z_{m-1}^i - \xi_{m-1}^i & \xi_{m-1}^i - z_{m-2}^i \end{bmatrix} \quad (13)$$

applied to \mathbf{P}^i . Similarly, equation (9) becomes

$$\mathbf{P}^n \simeq (\Delta z)^{n-1} \tilde{\Pi} \mathbf{J}^{n-1} \mathbf{I}^{n-1} \dots \tilde{\Pi} \mathbf{J}^2 \mathbf{I}^2 \tilde{\Pi} \mathbf{J}^1 \mathbf{I}^1 \mathbf{P}^1. \quad (14)$$

Matrix multiplications in previous equation are extremely time consuming. Indeed, while multiplying an m -vector by the $m \times m$ diagonal matrix \mathbf{J} requires m operations, and analogously for the \mathbf{I} operator, multiplication of the $\tilde{\Pi}$ matrix by a vector requires m^2 operations. On top of this, the procedure must be repeated at each time step. As a consequence, the dominant contribution grows as $n \times m^2$, and choosing a rather thick grid, computational time rapidly explodes. However, the multiplication of a Toeplitz matrix by a vector can be efficiently performed exploiting algorithms that are used in digital signal processing. By

embedding $\tilde{\Pi}$ into a circulant matrix of dimensions $2m \times 2m$

$$C = \begin{bmatrix} \tilde{\pi}_0 & \tilde{\pi}_1 & \dots & \tilde{\pi}_{m-1} & 0 & \tilde{\pi}_{m-1} & \tilde{\pi}_{m-2} & \dots & \tilde{\pi}_1 \\ \tilde{\pi}_1 & \tilde{\pi}_0 & \dots & \tilde{\pi}_{m-2} & \tilde{\pi}_{m-1} & 0 & \tilde{\pi}_{m-1} & \dots & \tilde{\pi}_2 \\ \vdots & \vdots & \ddots & \vdots & \vdots & \vdots & \ddots & \ddots & \vdots \\ \tilde{\pi}_{m-1} & \tilde{\pi}_{m-2} & \dots & \tilde{\pi}_0 & \tilde{\pi}_1 & \tilde{\pi}_2 & \dots & \dots & 0 \\ 0 & \tilde{\pi}_{m-1} & \dots & \tilde{\pi}_1 & \tilde{\pi}_0 & \tilde{\pi}_1 & \dots & \dots & \tilde{\pi}_{m-1} \\ \tilde{\pi}_{m-1} & 0 & \dots & \tilde{\pi}_2 & \tilde{\pi}_1 & \tilde{\pi}_0 & \tilde{\pi}_1 & \dots & \tilde{\pi}_{m-2} \\ \vdots & \vdots & \ddots & \vdots & \vdots & \vdots & \ddots & \ddots & \vdots \\ \tilde{\pi}_1 & \tilde{\pi}_2 & \dots & 0 & \tilde{\pi}_{m-1} & \tilde{\pi}_{m-2} & \dots & \tilde{\pi}_1 & \tilde{\pi}_0 \end{bmatrix}, \quad (15)$$

the product of $\tilde{\Pi}$ with a generic vector \mathbf{v} is equal to the first m components of $C\mathbf{v}_e$, $\mathbf{v}_e \in \mathbb{R}^{2m}$, $\mathbf{v}_e \doteq (\mathbf{v}^t, 0, \dots, 0)^t$. Every circulant matrix can be expressed as $C = U\Lambda U^*$, where U^* denotes the conjugate transpose of U , whose columns are $U^j = (1, e^{-\pi i j/m}, \dots, e^{-\pi i j(2m-1)/m})^t / \sqrt{2m}$ for $j = 0, \dots, 2m-1$, and $\Lambda = \text{diag}(C_0)$, with C_0 the first row of the circulant matrix. Thanks to this result, the product $C\mathbf{v}_e$ can be performed exploiting the fast Fourier transform (FFT) algorithm

$$C\mathbf{v}_e = \text{Re} [\mathcal{F}^{-1} (\mathcal{F}(C_0) \cdot \mathcal{F}(\mathbf{v}_e))],$$

where \mathcal{F} and \mathcal{F}^{-1} are the FFT and inverse FFT operator, respectively, while \cdot is the component wise product. With the adoption of this approach, the computational time is noticeably reduced: each FFT computation requires $O(m \times \log_2(2m))$ operations. Finally, in order to compute equation 14 we need to repeat the algorithm at each time step, and on the whole the computational burden can be estimated to be of order $O(n \times m \times \log_2 m)$, which is definitely a satisfactory improvement with respect to the non-FFT based procedure.

1.4 Fast convolution at work: numerical result

Equipped with FCA we are now ready to approach the multiplicative processes previously described. We want to check that the numerical results obtained by fast convolution converge to the analytical solution, when available, or to the PDF reconstructed by means of MC simulation. Moreover, we show that FCA provides an estimate of the distribution shape

even in those low probability regions, such as the tails, which are inefficiently sampled by the MC approach.

The Lamperti transform for process (2) can be explicitly computed as

$$Z_\tau = \int_{X_0}^{X_\tau} \frac{d\hat{X}_\tau}{\sqrt{c\hat{X}_\tau^2 + f\hat{X}_\tau + \tilde{e}(\tau)}} = \frac{1}{\sqrt{c}} \operatorname{asinh} \left(\frac{X_\tau + f/(2c)}{\sqrt{A_\tau^2}} \right) - \zeta_\tau^0, \quad (16)$$

with $A_\tau^2 = (4\tilde{e}_\tau c - f^2)/(4c^2)$, and $\zeta_\tau^0 = \operatorname{asinh}[(X_0 + f/(2c))/\sqrt{A_\tau^2}]/\sqrt{c}$.

The related drift function is

$$\mathbf{M}_Z(Z_\tau, \tau) = \frac{1}{\sqrt{c}} \left[\left(a - \frac{c}{2} \right) - \frac{\tilde{e}'_\tau}{2cA_\tau^2} \right] \tanh [\sqrt{c}(Z_\tau + \zeta_\tau^0)] - \frac{\frac{f}{2c} \left(a - \frac{c}{2} \right) - b + \frac{f}{4}}{\sqrt{cA_\tau^2} \cosh [\sqrt{c}(Z_\tau + \zeta_\tau^0)]} + \frac{\tilde{e}'_\tau}{2c^{\frac{3}{2}}A_\tau^2} \chi_\tau^0,$$

where $\chi_\tau^0 = (X_0 + f/(2c))/\sqrt{A_\tau^2 + (X_0 + f/(2c))^2}$, and the prime is a shorthand for the derivative w.r.t τ .

The first and simplest case we want to consider corresponds to the SDE (2) with time independent parameter $e > 0$, $D^2 > 0$, and negative a . Whenever these conditions are satisfied, the process converges exponentially to the stationary regime with a typical relaxation time given by $-1/a$. Following Biró and Jakovác (2005) the stationary PDF can be computed in closed-form as

$$P_{\text{st}}(x) \propto \frac{1}{\left[\left(x + \frac{f}{2c} \right)^2 + \frac{D^2}{4c^2} \right]^{\frac{1+\nu}{2}}} \exp \left[-2 \frac{af - 2bc}{c\sqrt{D^2}} \operatorname{atan} \left(\frac{x\sqrt{D^2}}{2e + fx} \right) \right], \quad (17)$$

with $\nu = 1 - 2a/c$, and the inverse tangent function continues smoothly at $x > -2e/f$. For illustrative purposes we fix the five free parameters as $a = -20$, $b = f = e = 0.1$, and $c = 4.5$, while the choices of $g(t)$ and t_0 are at the moment irrelevant since we work directly with time τ . As evident from equation (17) all moments of order n higher than or equal to ν diverge: as $\nu \simeq 9.9$, only the first nine lowest moments converge. In figure 1a we plot the time evolution of $\tilde{P}(z_\tau, \tau)$ for increasing values of $\tau = 0.01, 0.05, 0.1, 1$ as obtained by means of FCA ($z_{\min} = -10.24$, $m = 2^{13}$, $\Delta z = -2z_{\min}/m$, and $\Delta\tau = 10^{-3}$). For $\tau = 1$ we also plot the histogram corresponding to MC simulation of the discrete process (parameter of the Euler scheme approximation: $\Delta\tau = 10^{-3}$, and number of MC paths $N_{\text{MC}} = 10^6$),

while the solid line represents the analytical solution easily derived from equation 17. In figure 1b we show the same results in log-linear scale to emphasize the tail region. The analytical information provides an overall check that the algorithm converges to the correct distribution; however far from the stationary regime we have no precise information about the PDF shape. In Bormetti and Delpini (2010) the scaling of the convergent moments is computed analytically, but it is known that the knowledge of the moments does not allow for a unequivocal reconstruction of the complete distribution. We can only rely on MC simulation, but sampling of a low probability region requires on average a huge statistics (we need $N_{MC} > 1/p$ to explore a p -probability region). At this point the advantages provided by the fast convolution based approach are evident, as clearly shown by both panels. The FCA curve for $\tau = 1$ is in perfect agreement with the analytical prediction, both in central and tail regions. MC histograms agree as well, but these results are extremely noisy and very inaccurate for $\tilde{P}(z_\tau, \tau)10^{-4}$. FCA based results are even more impressive looking at the computational time. Performances are strongly machine dependent, and for this reason we do not quote absolute times, but measured relative values: to obtain $\tau = 1$ bars MC takes ten times longer than FCA⁴. As a consequence it needs 10^7 times longer to reach the same accuracy at the $\tilde{P}(z_\tau, \tau) \sim 10^{-10}$ level. Similar results are obtained for the slightly more complicated process used in Friedrich *et al.* (2000) to model foreign exchange rate fluctuations. Their process is still mean reverting with $a = -4.4 \times 10^{-1}$, $b = 0$, $c = 3.8 \times 10^{-2}$, and $f = 3.04 \times 10^{-3}$, though in this case the last parameter has a non trivial time dependence, $\tilde{c}(\tau) = 6.08 \times 10^{-5} + 6 \times 10^{-3} \exp(-0.5\tau)$. Since it lacks stationarity in this case, all analytical information on the PDF is lost, yet we can see from figures 2a and 2b how the numerical PDF evolves with time and we verify a striking matching between MC and FCA results. Remarks similar to the previous case apply.

We now turn our attention to piecewise linear diffusion. The procedure is in this case slightly subtle. Though the computation of the Lamperti transform of process (3) for

⁴Random number generators and FFT algorithms are provided by GNU Scientific Library.

$H = 1/2$ and integral time $\tau = 2\sqrt{t}$ does not involve problematic issues, resulting in ⁵

$$Z_\tau = \frac{2}{\sigma\varepsilon} \text{sign}(X_\tau) \left(\sqrt{\frac{\tau}{2} + \varepsilon|X_\tau|} - \sqrt{\frac{\tau}{2}} \right), \quad (18)$$

the stochastic differential dZ_τ cannot be computed applying Itô Lemma straightforwardly. As a function of X_τ and τ , Z_τ lacks necessary regularity conditions for $\tau = 0$ and $X_\tau = 0$. However, both difficulties can be overcome. The X_τ process does not suffer any problem at $\tau = 0$, therefore we can evolve from X^0 to X^1 , and then exploit the one-to-one correspondence between X_τ and Z_τ . Moving from $\tau = 0$ to $\tau = \Delta\tau$, X^1 remains delta distributed around zero, and the same holds true for Z^1 . For $\tau \geq \Delta\tau$ the time derivative $\partial Z_\tau / \partial \tau$ needed in dZ_τ can be readily computed. The difficulty that arises with the computation of $\partial^2 Z_\tau / \partial X_\tau^2$ at zero can be dealt with replacing the absolute value with the smooth approximation

$$|X_\tau|_s \doteq X_\tau \left(\frac{2}{1 + e^{-2kX_\tau}} - 1 \right).$$

This allows us to compute

$$\frac{d}{dX_\tau} |X_\tau|_s = \left(\frac{2}{1 + e^{-2kX_\tau}} - 1 \right) + 4kX_\tau \frac{e^{-2kX_\tau}}{(1 + e^{-2kX_\tau})^2},$$

where the right term, for sufficiently large k , is approximately equal to $\text{sign}(X_\tau)$ (as can be verified by direct inspection). In order to derive the dynamics of Z_τ we need to invert equation (18)

$$X_\tau = \text{sign}(Z_\tau) \frac{1}{\varepsilon} \left[\left(\frac{\sigma\varepsilon}{2} |Z_\tau| + \sqrt{\frac{\tau}{2}} \right)^2 - \frac{\tau}{2} \right], \quad (19)$$

and to compute the drift coefficient by means of equation (8). After straightforward calculations, we eventually obtain the following expression

$$dZ_\tau \simeq \text{sign}(Z_\tau) \left[\frac{1}{2\varepsilon} \left(\frac{1}{\frac{\sigma^2\varepsilon}{2} |Z_\tau| + \sigma\sqrt{\frac{\tau}{2}}} - \frac{1}{\sigma\sqrt{\frac{\tau}{2}}} \right) - \frac{\varepsilon\sigma^2}{4} \frac{1}{\frac{\sigma^2\varepsilon}{2} |Z_\tau| + \sigma\sqrt{\frac{\tau}{2}}} \right] d\tau + dW_\tau.$$

Numerical results concerning this last process are reported in figure 3a (linear scale) and in figure 3b (log-linear scale). We study the dependence of $\tilde{P}(z, \tau)$ on $1/(\sigma^2\varepsilon)$. Indeed for $|x| \gg 1$, $P(x, \tau) \sim \exp[-2|x|/(\sigma^2\varepsilon\tau)]$, and the value of the coefficient in the exponential function is crucial to assess the convergence of the expectation of $\exp(x)$ with respect to

⁵The sign function is defined according to the convention $\text{sign}(0) = 0$.

$P(x, \tau)$. We fix $\tau = 1$, $\sigma^2 = 1$, and $\varepsilon = 0.5, 1, 2$. The leptokurtosis of the PDF increases as far as the value of ε increases. Parameters for the Euler scheme approximation are fixed as in previous examples, while for the FCA we have slightly changed the value of $\Delta\tau = 10^{-4}$ and $m = 2^{11}$ keeping $z_{\min} = -10.24$. For each one of the three cases we also plot the analytical prediction, since for piecewise linear processes the solution is known in closed form. Also in this last case there is good agreement between analytical and fast convolution PDF, while limitations of the MC approach due to the finite statistics are evident from the symbols depicted in Panel (b).

1.5 Financial applications

In the second part of this work we present and discuss how the results achieved in the previous sessions can be exploited in finance, and in particular in the context of option pricing. For both quadratic and piecewise diffusion we briefly review how to set the correct risk neutral framework. Then, for explanatory purposes, we apply the FCA to price European Plain Vanilla and geometric Asian options, but the approach can be extended to deal with different payoffs and different kinds of boundary conditions. For the remainder of this paper, $X_t = \ln S_t - \ln S_0$ is the logarithmic return obtained from the stochastic process S_t describing the evolution of an asset price. As asset candidates we only consider equities and foreign exchange rates.

1.6 A piecewise diffusion under risk-neutrality: Plain Vanilla pricing

According to risk neutral valuation theory we need to find the dynamics of S_t or, equivalently, X_t under the probability measure which makes all discounted asset prices martingales. Whenever the Novikov condition for the process under consideration is verified, the Girsanov theorem gives the recipe for the equivalent measure, and it also explains how the dynamics of S_t coherently modifies. However, McCauley and Gunaratne (2003); McCauley *et al.* (2007b) show how to compute the desired martingale directly from the Green function

solving the FP equation associated to the dynamics

$$dS_t = \mu S_t dt + \sigma S_t \sqrt{1 + \varepsilon \frac{|\ln S_t - \ln S_{t_0}|}{\sqrt{t}}} dW_t, \quad (20)$$

with $S_{t_0} = S_0$. Just in the case of the original model of Black and Scholes (1973); Merton (1973), a delta hedged strategy allows us to construct a locally risk neutral portfolio and to derive the partial differential equation

$$\frac{\partial O}{\partial t} + r S_t \frac{\partial O}{\partial S_t} + \sigma^2 S_t^2 \frac{\sqrt{t} + \varepsilon |\ln S_t - \ln S_0|}{2\sqrt{t}} \frac{\partial^2 O}{\partial S_t^2} - r O = 0, \quad (21)$$

that is to be used to solve the pricing problem of a Plain Vanilla option O , with a risk free interest rate r and for suitable boundary conditions. Introducing $\hat{O}(S_t, t) \doteq e^{r(T-t)} O(S_t, t)$ and substituting in equation 21, it is readily verified that the hat price satisfies an equation formally identical to the backward time FP equation associated with the dynamics 20 with $\mu = r$. The fair price of a call option is therefore predicted to be

$$O(S_0, t_0) = e^{-r(T-t_0)} \int_{-\infty}^{+\infty} dS_T (S_T - K)^+ G^{\mathbb{Q}}(S_T, T; S_0, t_0) = e^{-r(T-t_0)} \mathbb{E}^{\mathbb{Q}} [(S_T - K)^+ | S_0],$$

where $G^{\mathbb{Q}}$ is the Green function solving the FP equation in the risk neutral framework, and K is the strike price. The dynamics of X_t under the new probability measure reads

$$dX_t = \left[r - \frac{\sigma^2}{2} \left(1 + \varepsilon \frac{|X_t|}{\sqrt{t}} \right) \right] dt + \sigma \sqrt{1 + \varepsilon \frac{|X_t|}{\sqrt{t}}} dW_t^{\mathbb{Q}}, \quad X_{t_0} = 0. \quad (22)$$

At variance with equation (3), a non trivial drift term appears and some comments are mandatory. As recognized by McCauley and collaborators, whenever the drift depends explicitly on X_t there is no way to preserve scaling properties. However, in order to exploit the analytical information provided by equation (6), corresponding to the Green function $G^{\mathbb{Q}}(X_T, T; 0, 0)$ for the process (3), they replace the drift with a constant. We are instead equipped with a computationally efficient algorithm, and so we can get rid of this approximation and price options directly with the process (22). As in section 1.2, we switch to integral time

$$dX_\tau = \left(r - \frac{\sigma^2}{2} \right) \frac{\tau}{2} d\tau - \frac{\varepsilon \sigma^2}{2} |X_\tau| d\tau + \sigma \sqrt{\frac{\tau}{2} + \varepsilon |X_\tau|} dW_\tau^{\mathbb{Q}}, \quad X_0 = 0,$$

and compute the Call option price as

$$\begin{aligned}
O(S_0, t_0) &= S_0^D \mathbb{E}^{\mathbb{Q}} \left[(e^{X_{\tau(T)}} - e^k)^+ | \mathbf{X}_0 \right] \\
&= S_0^D \mathbb{E}^{\mathbb{Q}} \left[(e^{X(Z_{\tau(T)})} - e^k)^+ | \mathbf{Z}_0 \right] \\
&= S_0^D \int_{-\infty}^{+\infty} dz_{\tau(T)} \left[e^{\text{sign}(z_{\tau(T)}) \frac{1}{\varepsilon} \left[\left(\frac{\sigma \varepsilon}{2} |z_{\tau(T)}| + \sqrt{\frac{\tau(T)}{2}} \right)^2 - \frac{\tau(T)}{2} \right]} - e^k \right]^+ p^{\mathbb{Q}}(z_{\tau(T)} | z_0) \\
&\simeq S_0^D \Delta z \sum_{j=0}^{m-1} \left[e^{\text{sign}(z_{\min} + j \Delta z) \frac{1}{\varepsilon} \left[\left(\frac{\sigma \varepsilon}{2} |z_{\min} + j \Delta z| + \sqrt{\frac{n \Delta \tau}{2}} \right)^2 - \frac{n \Delta \tau}{2} \right]} - e^k \right]^+ \mathbf{P}_j^{\mathbb{Q}}, \tag{23}
\end{aligned}$$

with $\tau(T) = 2\sqrt{T}$, discounted price $S_0^D = e^{-r(T-t_0)} S_0$ and log-moneyness $k = \ln(K/S_0)$. In the third line of above equation we have made explicit the expectation in terms of the risk neutral PDF associated to the process $Z_{\tau(T)}$, and we have substituted the expression of X_{τ} as a function of Z_{τ} given by equation (19). The vector $\mathbf{P}_j^{\mathbb{Q}}$ of transition probability between z_0 and z_j^n under the risk neutral measure \mathbb{Q} has to be computed with the fast convolution procedure described in section 1.3.

1.7 Exotic options: the geometric Asian case

Formula (23) can be extended to deal with payoffs with different dependence on S_{τ} , e.g. digital options, covered call or strongly non-linear function $f(S_{\tau})$, the only constraint being $\mathbb{E}^{\mathbb{Q}}[f(S_{\tau}) | S_0] < \infty$. The case of a functional payoff depending multiplicatively on the price along the path, i.e. $f([S_{\tau}]) = \prod_{i=0}^n f_i(S^i)$, is just slightly more complicated but in fact can be easily managed, see Chiarella and El-Hassan (1997) for an application to bond pricing. In this section, we address the problem of pricing a geometric Asian option, which requires the computation of the expected value

$$\mathbb{E}^{\mathbb{Q}} \left[\left(e^{\frac{1}{T-t_0} \int_{t_0}^T \ln S_s ds} - K \right)^+ | S_0 \right]. \tag{24}$$

As the positive part function is non-linear, the previous expression is quite tricky to evaluate and requires some careful manipulations. Defining $\tau = 2(\sqrt{t} - \sqrt{t_0})$, the Asian price is given by

$$O_A(S_0, t_0) = S_0^D \mathbb{E}^{\mathbb{Q}} \left[\left(e^{\frac{1}{T-t_0} \int_0^{\tau(T)} \left(\frac{\tau'}{2} + \sqrt{t_0} \right) X_{\tau'} d\tau'} - e^k \right)^+ | \mathbf{X}_0 \right]. \tag{25}$$

We exploit the discretization of the $\tau(T)$ time interval in n equally spaced intervals of amplitude $\Delta\tau$, and we replace the integral expression with a finite sum $U^n \doteq \sum_{j=1}^n (j\Delta\tau/2 + \sqrt{t_0})x^j/n$. We then introduce the ancillary variables $\{U^1, \dots, U^n\}$ satisfying the following recursion relation

$$U^{i+1} = \frac{i}{i+1}U^i + \left(\frac{\Delta\tau}{2} + \frac{\sqrt{t_0}}{i+1}\right)X^{i+1}, \quad (26)$$

for $i = 1, \dots, n-1$ and $U^1 = \left(\frac{\Delta\tau}{2} + \sqrt{t_0}\right)X^1$. Exploiting the one-to-one correspondence between X_τ and Z_τ , it is possible to rewrite the Asian price as

$$O_A(S_0, t_0) = S_0^D \int_{u^n} du^n A(u^n) p_U^{\mathbb{Q}}(u^n) = S_0^D \int_{u^n} du^n \int_{z^n} dz^n A(u^n) p_{UZ}^{\mathbb{Q}}(u^n, z^n),$$

with $A(u^n) = \left(e^{2\frac{\sqrt{\tau}-\sqrt{t_0}}{T-t_0}u^n} - e^k\right)^+$. The only unknown quantity in the previous expression is the joint distribution of U^n and Z^n , whose computation requires a recursion relation allowing us to propagate $p_{UZ}^{\mathbb{Q}}(u^i, z^i)$ to $p_{UZ}^{\mathbb{Q}}(u^{i+1}, z^{i+1})$ with the associated initial time condition $p_{UZ}^{\mathbb{Q}}(u^1, z^1) = \delta(z^1)\delta(u^1)$. The following equation holds

$$p_{UZ}^{\mathbb{Q}}(u^i, z^{i+1}) = \int_{z^i} dz^i p_{UZ}^{\mathbb{Q}}(u^i, z^i) \pi^{\mathbb{Q}}(z^{i+1}|z^i), \quad (27)$$

and to proceed it is useful to make explicit the dependence of X^{i+1} on Z^{i+1} in equation (26)

$$\begin{cases} U^{i+1} = \frac{i}{i+1}U^i + \left(\frac{\Delta\tau}{2} + \frac{\sqrt{t_0}}{i+1}\right) \text{sign}(Z^{i+1}) \frac{1}{\varepsilon} \left[\left(\frac{\sigma\varepsilon|Z^{i+1}|}{2} + \sqrt{\frac{\tau}{2}}\right)^2 - \frac{\tau}{2} \right] \\ Z^{i+1} = Z^{i+1}, \end{cases} \quad (28)$$

where U^{i+1} is coupled with the dummy variable Z^{i+1} . From previous relations we have

$$p_{UZ}^{\mathbb{Q}}(u^{i+1}, z^{i+1}) = \left| \frac{\partial(u^i, z^{i+1})}{\partial(u^{i+1}, z^{i+1})} \right| p_{UZ}^{\mathbb{Q}}(u^i(u^{i+1}, z^{i+1}), z^{i+1}), \quad (29)$$

where the Jacobian is equal to $(i+1)/i$. Therefore starting from the distribution $p_{UZ}^{\mathbb{Q}}(u^1, z^1)$, and following the above procedure, after $n-1$ steps we obtain the desired $p_{UZ}^{\mathbb{Q}}(u^n, z^n)$. Introducing an m_Z -node grid for Z^i and an m_U -node grid for U^i , we can approximate the distribution $p_{UZ}^{\mathbb{Q}}(u^i, z^i)$ with an $m_U \times m_Z$ matrix \mathbf{P}_{jk}^i , the row index j running over the nodes of U^i , the column index k over those of Z^i . The Asian price can therefore be approximated by

$$O_A(S_0, t_0) \simeq S_0^D \Delta u \Delta z \sum_{j=0}^{m_U-1} A(u_j^n) \sum_{k=0}^{m_Z-1} \mathbf{P}_{jk}^n.$$

Since the time evolution corresponding to equation (27) is the most computationally intensive operation implicit in previous approximation, we can perform it at each node u_j^i by means of FCA. The overall numerical complexity of the algorithm is essentially linear in the total number of grid nodes, i.e $O(n \times m_U \times m_Z \log_2 m_Z)$.

1.8 The Vellekoop-Nieuwenhuis-Borland model

The geometric Asian case just described is useful also in view of the last application we present, which is related to the model for the stock price dynamics introduced in Borland (2002a,b, 2007). The Borland model tries to generalize the standard Black&Scholes to account for the empirical evidence of fat tailed return distributions and volatility smile, still keeping a closed form formula for the price of Plain Vanilla instruments. It is a hybrid between stochastic volatility models and the standard Black&Scholes: the volatility is stochastic, but the stock price and the volatility itself are driven by the same Brownian motion. Analogies between the dynamics of turbulent flows in physics and that of financial returns, bring Borland to make use of stochastic processes with statistical feedback, processes originally developed in the thermostatics context, in order to describe historical returns. Statistical feedback processes are generalization of the Wiener noise: their probability density function is a Tsallis distribution, which depend parametrically on an index q , originally called entropic index. Standard Brownian motion with normally distributed returns corresponds to the case $q = 1$. Borland (2002a) instead shows that by choosing $q = 3/2$, not only empirical distribution of several financial time series (S&P500 index, foreign exchange rates, stock prices, ...) are satisfactorily fitted, but also the cumulative probability density function associated to this family of stochastic processes display power tails (of index 3), this latter feature known to be an empirical regularity for many complex systems, besides economics and finance⁶. Despite its theoretical elegance, the Borland model has been widely questioned. As firstly pointed out by McCauley and collaborators, Borland's scaling version of the Tsallis dynamics reduces to equation (1) through a suitable

⁶Gabaix (2009) comprehensively reviews power law regularity in economics and finance, while Gabaix *et al.* (2003) propose a model providing theoretical explanation.

specification of $g(t)$, a , b , c , f , and the deterministic function $e(t)$, (see McCauley *et al.*, 2007a, section 7) and Borgetti and Delpini (2010). Therefore, instead of a feedback mechanism, it would be more correct to speak of a local volatility model. Moreover, Vellekoop and Nieuwenhuis (2007) have raised two main objections to the Borland model by proving that it suffers from arbitrage opportunities and diverging payoff expectation, as a consequence of the thickness of the tails. However, Vellekoop and Nieuwenhuis have preserved the main ideas of the model and they have proposed a modified version amended from all drawbacks. In their version stock prices follow the dynamics

$$dS_t = \mu S_t dt + \sigma S_t d\Omega_t, \quad S_{t_0} = S_0, \quad (30)$$

$$d\Omega_t = \Sigma(\Omega_t, t) dW_t, \quad \Omega_{t_0} = \Omega_0, \quad (31)$$

with

$$\Sigma(\Omega_t, t) = \begin{cases} A^{-\frac{\alpha}{2}} P(\Omega_t, t)^{-\frac{\alpha}{2}} & t > 0 \\ 0 & t = 0, \end{cases} \quad \text{and} \quad P(\Omega_t, t) = \frac{1}{N_t} (1 + \alpha \beta_t \Omega_t^2)^{-\frac{1}{\alpha}}, \quad (32)$$

with $\beta_t = [(1 - \alpha)(2 - \alpha)t]^{-\frac{2}{2-\alpha}}$, $N_t = A/\sqrt{\beta_t}$, $A = \sqrt{\frac{\pi}{\alpha}} \Gamma(\frac{1}{\alpha} - \frac{1}{2}) / \Gamma(\frac{1}{\alpha})$, $\alpha \in (0, \frac{1}{2})^7$, and $t_0 \geq 0$. In Vellekoop and Nieuwenhuis (2007) the existence of a solution for equation 31 is proved, and it is shown how the unconditional distribution (i.e. $\Omega_{t_0} = 0$ for $t_0 = 0$) reduces to the generalized Student- t distribution. In general the conditional distribution deviates from it. The log-return X_t satisfies the equation

$$X_T = X_t + \mu(T - t) - \frac{1}{2} \sigma^2 \int_t^T \Sigma^2(s, \Omega_s) ds + \sigma(\Omega_T - \Omega_t),$$

for $T > t \geq t_0$. They verify that sufficient conditions hold for the applicability of the Girsanov theorem, and they derive the risk neutral dynamics

$$dS_t = r S_t dt + \sigma S_t d\Omega_t^{\mathbb{Q}}, \quad \text{with} \quad d\Omega_t^{\mathbb{Q}} = \Sigma(\Omega_t, t) dW_t^{\mathbb{Q}}. \quad (33)$$

This last process does not suffer any of the previous problems, however S_t (as a 1-D process) does not satisfy the Markov property, but does when considered jointly with Ω_t . In addition,

⁷The relation between Borland's parameter q and α is given by $q = \alpha + 1$.

the price of Plain Vanilla instruments cannot be given as a closed form formula. Indeed, according to pricing theory we have

$$O_C(S_0, \Omega_0, t_0) = S_0^D \mathbb{E}^{\mathbb{Q}} \left[\left(e^{r(T-t_0) + \sigma(\Omega_T - \Omega_0) - \frac{1}{2}\sigma^2 \int_{t_0}^T \Sigma^2(\Omega_s, s) ds} - e^k \right)^+ \middle| S_0, \Omega_0 \right],$$

and the expectation can only be computed via numerical techniques.

Given 32, we observe that the equation governing the evolution of $d\Omega_t^{\mathbb{Q}}$ belongs to the class of quadratic diffusion processes 1 through the identifications $a = b = f = 0$, $c = \alpha / [(1 - \alpha)(2 - \alpha)]$, $e(t) = [(1 - \alpha)(2 - \alpha)]^{\frac{\alpha}{2-\alpha}} t^{2/(2-\alpha)}$, and $g(t) = t$. Switching to the integral time $\tau = \ln t / t_0$ for $t_0 > 0$, and recalling equation 16, Z_τ is readily computed

$$Z_\tau = \frac{1}{\sqrt{c}} [\operatorname{asinh}(C_{\alpha, t_0, \tau} \Omega_\tau) - \operatorname{asinh}(C_{\alpha, t_0, \tau} \Omega_0)], \quad (34)$$

where $C_{\alpha, t_0, \tau} = \sqrt{\alpha \beta_{t_0}} e^{-\tau/(2-\alpha)}$. The price of a Plain Vanilla instrument can be computed as

$$O_C(S_0, Z_0, t_0) = S_0^D \mathbb{E}^{\mathbb{Q}} \left[\left(e^{r(T-t_0) + \sigma[\Omega(Z_{\tau(T)}) - \Omega(Z_0)] - \frac{(2-\alpha)\sigma^2}{4}[e(T) - e(t_0)] - \frac{c\sigma^2}{2} \int_0^{\tau(T)} \Omega(Z_{t'})^2 dt'} - e^k \right)^+ \middle| S_0, Z_0 \right] \quad (35)$$

with $\tau(T) = \ln T - \ln t_0$. Defining the set of ancillary variables $\{U^1, \dots, U^n\}$ satisfying the recursive relation

$$U^{i+1} = U^i + \Delta\tau\Omega(Z^{i+1})^2, \quad (36)$$

with $U^1 = \Delta\tau\Omega(Z^1)^2$, the formal analogy with the Asian case discussed in the previous section is evident. Computation of the expectation in 35 requires estimation of the joint probability $p_{UZ}^{\mathbb{Q}}(u^n, z^n)$. The procedure is identical to the Asian case; equation (27) is still valid, while the system (28) has to be coherently modified in

$$\begin{cases} U^{i+1} = U^i + \frac{\Delta\tau}{C_{\alpha, t_0, (i+1)\Delta\tau}^2} \sinh^2 [\sqrt{c}Z^{i+1} + \operatorname{asinh}(C_{\alpha, t_0, (i+1)\Delta\tau} \Omega(Z_0))] \\ Z^{i+1} = Z^i. \end{cases}$$

The Jacobian in equation 29 simplifies to one, and, eventually, we can approximate the Plain Vanilla price as

$$O_C(S_0, Z_0, t_0) \simeq S_0^D \Delta u \Delta z \sum_{j=0}^{m_U-1} \sum_{k=0}^{m_Z-1} C(u_j^n, z_k^n) \mathbf{P}_{jk}^i{}^{\mathbb{Q}},$$

where $C(u_j^n, z_k^n) = \left(e^{r(T-t_0) - \frac{\sigma^2}{2} \int_{t_0}^T \beta_s^{-\alpha/2} ds + \sigma[\Omega(z_k^n) - \Omega(z_0)] - \frac{\alpha\sigma^2}{2(1-\alpha)(2-\alpha)} u_j^n} - e^k \right)^+$, and compute it by means of a fast convolution.

1.9 Numerical results

In this final section we sum up numerical results for the financial applications described in paragraphs 1.6, 1.7, and 1.8.

Whenever we switch to the risk neutral measure for the piecewise linear process, corrections terms in the SDE appear and an analytical expression for the density is no longer available. Numerical simulation is mandatory, and the FCA algorithm, being both faster and much more efficient, is a natural competitor to the MC approach. The transformed Z_τ process is enriched by the risk neutral correction (the second last term in the squared brackets)

$$dZ_\tau \simeq \text{sign}(Z_\tau) \left[\frac{1}{2\varepsilon} \left(\frac{1}{\frac{\sigma^2\varepsilon}{2}|Z_\tau| + \sigma\sqrt{\frac{\tau}{2}}} - \frac{1}{\sigma\sqrt{\frac{\tau}{2}}} \right) - \frac{\varepsilon\sigma^2}{4} \frac{1}{\frac{\sigma^2\varepsilon}{2}|Z_\tau| + \sigma\sqrt{\frac{\tau}{2}}} - \frac{1}{2} \left(\frac{\sigma^2\varepsilon}{2}|Z_\tau| + \sigma\sqrt{\frac{\tau}{2}} \right) + \frac{r}{\frac{\sigma^2\varepsilon}{2}|Z_\tau| + \sigma\sqrt{\frac{\tau}{2}}} \right] d\tau + dW_\tau,$$

where r is the risk free rate. In figures 4a and 4b we draw risk neutral PDFs for $r = 0.03$ and remaining parameters as in figures 3a and 3b. The effect of the additional terms is evident from their comparison. In particular, the increase of the skewness induced by the risk neutral correction from linear plots in Panel (a) is remarkable. Turning our attention to the pricing of Asian options, Figure 5a plots the joint density $p_{U,Z}^\mathbb{Q}(u, z)$, and associated marginals for $t_0 = 0$, $\tau = 1$, $\sigma^2 = 1$, and $\varepsilon = 2$. Parameters of the fast convolution are $z_{\min} = -10.24$, $m_Z = 2^{10}$, $u_{\min} = -2.56$, $m_U = 2^{11}$, and $\Delta\tau = 10^{-3}$. In figure 5b we compare the marginal PDF of Z_τ , and analogously to paragraph 1.4 the agreement between FCA and MC is striking in the central region.

As far as the pricing under the Vellekoop-Nieuwenhuis-Borland model is concerned, we start plotting in figure 6a the joint bivariate density $p_{U,Z}^\mathbb{Q}(u, z)$ for parameter values $z_{\min} = -10.24$, $m_Z = 2^{10}$, $u_{\min} = -5.12$, $m_U = 2^{11}$, $\Delta\tau = 10^{-3}$, $\Omega_0 = 0$, $\alpha = 0.1$, $t_0 = 0.2$, and $T = 0.7$. We notice that the fast convolution algorithm correctly predicts a non negative support for the U_τ variable, even though the numerical grid spans uniformly the interval

$[u_{\min}, -u_{\min}]$. In figure 6b we compare the distribution of Z_τ obtained by means of FCA and MC, finding a perfect match, and we also plot the PDF of Ω , easily derived given the relationship between the two variables, see equation (34). In light of the agreement between the two numerical procedures, we can use the FCA approach to efficiently price European Call options, as explained in paragraph 1.8. In this respect in figures 7a, 7b, 8a, and 8b we present our results in terms of implied Black-Scholes volatilities. Our choices of the parameters are $S_{t_0} = 100$, $r = 0.03$, $\sigma = 0.3$, $t_0 = 0.2$, $\Omega_0 = 0, 0.5$, $\alpha = 0.1, 0.4$, $K \in [70, 130]$, and $T - t_0 \in [0.5, 2]$. MC bands at 95% Confidence Level are plotted as dashed lines for the shortest time to maturity, $T - t_0 = 0.5$ with $N_{\text{MC}} = 5 \times 10^7$. FCA and MC volatility curves are fully consistent. As expected surfaces exhibit a volatility smile, more pronounced for small maturities and for Ω_0 values deviating from zero. As already pointed out by Vellekoop and Niueuwenhuis, a wider variety of volatility surfaces and flexibility of the model can be obtained by manipulating the different values of Ω_0 .

1.10 Conclusion

In this paper we have addressed the problem of investigating performances of the fast convolution algorithm introduced by Eydeland (1994). Choosing different specifications of the stochastic process, this has been carried out both with the reconstruction of conditional probability densities at different time horizons and with the computation of prices of financial derivatives. FCA is an efficient grid algorithm relying on restating functional integrals as sequences of ordinary finite dimensional integrals, and on converting the stochastic process to a unitary diffusion one by means of the Lamperti transform. A reformulation of the problem, then, allows those integrals to be evaluated efficiently by the use of fast Fourier transform techniques.

The stochastic processes we have investigated belong to two classes of multiplicative noise processes: the family of quadratic diffusion, see Bormetti and Delpini (2010); Delpini and Bormetti (2010), and piecewise linear diffusions, see Alejandro-Quiñones *et al.* (2006); McCauley and Gunaratne (2003). The analysis performed in this work provides a natural complement to the analytical results obtained in Bormetti and Delpini (2010), where closed

form solutions for the stationary PDF and for the convergent moments at arbitrary time had been obtained. We have detailed a step by step numerical procedure able to provide an accurate estimate for the probability distribution of the process even far from the stationary regime. Similar results have been found for the piecewise diffusion. In this latter case, if the dynamics is enriched with a non trivial drift term, scaling properties are no longer preserved and all analytical information is lost. Since this is exactly the situation we faced when switching to the risk neutral setting, FCA proved to be a very efficient and reliable approach to the problem of option pricing. A detailed empirical analysis for different specifications of the parameter values documents the superiority of the FCA approach to standard Monte Carlo simulations. We have also demonstrated the flexibility of the approach when dealing with exotic instruments, and exploited the formal analogy between geometric Asian option pricing and Plain Vanilla pricing under the Vellekoop-Nieuwenhuis-Borland dynamics. As it is an interesting hybrid between a geometric Brownian motion and a stochastic volatility model, the latter provides a realistic description of the dynamics implied in the option market. FCA is able to numerically reproduce a rich variety of implied volatility surfaces improving the standard Monte Carlo approach.

Since, as we have documented, FCA turns out to be highly successful also in the case of the Vellekoop-Nieuwenhuis-Borland model, a natural perspective is to concentrate future research efforts on the extension of FCA to higher dimensional stochastic systems. This is precisely the case of continuous time stochastic volatility models, see Fouque *et al.* (2000). These models provide a flexible framework when modeling volatility, and they allow us to reproduce several observed statistical regularities. For this reason they are nowadays extensively exploited by quantitative sectors of banks and financial institutions. Given the ability of the fast convolution to reconstruct densities over tail regions, and of the investigated models to generate leptokurtic and scaling distributions, the present approach is naturally suited for application in the context of financial risk management, e.g. Value-at-Risk and coherent risk measures computation, see Bormetti *et al.* (2010, 2007); Jorion (2007); McNeil *et al.* (2005).

References

- Alejandro-Quiñones, A. L., Bassler, K. E., Field, M., McCauley, J. L., Nicol, M., Timofeyev, I., Török, A. and Gunaratne, G. H., 2006, A theory of fluctuations in stock prices. *Physica A*, **363**, 383–392.
- Baaqui, B. E., 2007, *Quantum Finance: Path Integrals and Hamiltonians for Options and Interest Rates* (Cambridge: Cambridge University Press).
- Baldovin, F., and Stella, A. L., 2007, Scaling and efficiency determine the irreversible evolution of a market. *Proc. Natl. Acad. Sci.*, **104**, 19741–19744.
- Biró, T. S., and Jakovác, A., 2005, Power-Law tails from multiplicative noise. *Phys. Rev. Lett.*, **94**, 132302-1–4.
- Black, F. , and Scholes, M., 1973, The pricing of options and corporate liabilities. *J. Political Econ.*, **8**, 637–654.
- Bollerslev, T., 1986, Generalized autoregressive conditional heteroskedasticity. *J. Econometrics*, **31**, 307–327.
- Borland, L., 1998, Microscopic dynamics of the nonlinear Fokker-Planck equation: A phenomenological model. *Phys. Rev. E*, **57**, 6634-6642.
- Borland, L., 2002a, Option pricing formulas based on a non-Gaussian stock price model. *Phys. Rev. Lett.*, **89**, 098701-01.
- Borland, L., 2002b, A theory of non-Gaussian option pricing. *Quant. Finance*, **2**, 415–431.
- Borland, L., 2007, Erratum: A theory of non-Gaussian option pricing. *Quant. Finance*, **7**, 701.
- Borland, L., Bouchaud, J. P., Muzy, J. F. and Zumbach, G., 2005, The dynamics of financial markets: Mandelbrot’s multifractal cascades, and beyond. *Wilmott Magazine*.

- Bormetti, G., Cazzola, V., Livan, G., Montagna, G. and Nicosini, O., 2010, A generalized Fourier transform approach to risk measures. *J. Stat. Mech.*, P01005.
- Bormetti, G., Cisana, E., Montagna, G. and Nicosini, O., 2007, A non-Gaussian approach to risk measures. *Physica A*, **376**, 532–542.
- Bormetti, G., and Delpini, D., 2010, Exact moment scaling from multiplicative noise. *Phys. Rev. E*, **81**, 032102-1–4.
- Bormetti, G., Montagna, G., Moreni, N. and Nicosini, O., 2006, Pricing exotic options in a path integral approach. *Quant. Finance*, **6**, 55–66.
- Bouchaud, J., P. and Potters, M., 2003, *Theory of Financial Risk and Derivative Pricing: from Statistical Physics to Risk Management*, (Cambridge: Cambridge University Press).
- Brandimarte P., 2006, *Numerical Methods in Finance and Economics*, (Hoboken: John Wiley & Sons).
- Campbell, J., Lo, A. H. and McKinlay, C., 1997, *The Econometrics of Financial Markets*, (Princeton: Princeton University Press).
- Chaudhary, S. K., 2007, A simple American option pricing method using the fast Fourier transform. *Int. J. Theor. App. Finance*, **10**, 1–12.
- Chiarella, C., and El-Hassan, N., 1997, Evaluation of derivative security prices in the Heath-Jarrow-Morton framework as path integrals using fast Fourier transform techniques. *J. Finan. Engineering*, **6**, 121–147.
- Cont, R., 2001, Empirical properties of asset returns: stylized facts and statistical issues. *Quant. Finance*, **1**, 223–236.
- Dash, J., 1989, Path integrals and options, Parts I, II, Centre Nationale de la Recherche Scientifique.
- Delpini, D., and Bormetti, G., 2011, Minimal model of financial stylized facts. *Phys. Rev. E*, **83**, 041111-1–4.

- Eydeland, A., 1994, A fast algorithm for computing integrals in function spaces: financial applications. *Computational Econ.*, **7**, 277–285.
- Engle, R. F., 1982, Autoregressive conditional heteroskedasticity with estimates of the variance of United Kingdom inflation. *Econometrica*, 1982, **50**, 987–1007.
- Fama, E. F., 1965, The behavior of stock market prices. *J. Bus.*, **84**, 34–105.
- Friedrich, R. and Peinke, J. , 1997, Description of a turbulent cascade by a Fokker-Planck equation. *Phys. Rev. Lett.*, **78**, 863–866.
- Friedrich, R., Peinke, J. and Renner, C., 2000, How to quantify deterministic and random influences on the statistics of the foreign exchange market. *Phys. Rev. Lett.*, **84**, 5224–5227.
- Fouque, J. P., Papanicolaou, G. and Sircar, K. R., 2000, *Derivatives in Financial Markets with Stochastic Volatility* (Cambridge: Cambridge University Press).
- Gabaix, X., Gopikrishnan, P., Plerou, V., Stanley, E., 2003, A theory of power-law distributions in financial market fluctuations. *Nature*, **423**, 267–270.
- Gabaix, X., 2009, Power Laws in Economics and Finance. *Annu. Rev. Econ.*, **1**, 255–293.
- Ghashghaie, S., Breymann, W., Peinke, J., Talkner, P. and Dodge, Y., 1996, Turbulent cascades in foreign exchange markets. *Nature*, **381**, 767–770.
- Ghasemi, F., Sahimi, M., Peinke, J. and Thaimi, M. R. R., 2006, Analysis of non-stationary data for heart-rate fluctuations in terms of drift and diffusion coefficients. *J. Biol. Phys.*, **32**, 117–128.
- Iacus, S. M., 2008, *Simulation and Inference for Stochastic Differential Equations*, (New York: Springer).
- Jorion, P., 2007, *Value at Risk: The New Benchmark for Managing Financial Risk*, (New York: McGraw-Hill).

- Mandelbrot, B., 1963, The variation of certain speculative prices. *J. Bus.*, **36**, 394–419.
- Mandelbrot, B., 1997, *Fractals and Scaling in Finance: Discontinuity, Concentration and Risk*, (New York: Springer).
- Mantegna, R. N. and Stanley, H. E., 2004, *An Introduction to Econophysics: Correlations and Complexity in Finance*, (Cambridge: Cambridge University Press).
- Mantegna, R. N. and Stanley, H. E., 1995, Scaling behaviour in the dynamics of an economic index, *Nature*, **376**, 46–49.
- McCauley, J. L., 2004, *Dynamics of Markets: Econophysics and Finance*, (Cambridge: Cambridge University Press).
- McCauley, J. L. and Gunaratne, G. H., 2003, An empirical model of volatility of returns and option pricing. *Physica A*, **329**, 178–198.
- McCauley, J. L., Gunaratne, G. H. and Bassler, K. E., 2007a, Hurst exponents, Markov processes, and fractional Brownian motion. *Physica A*, **379**, 1–9.
- McCauley, J. L., Gunaratne, G. H. and Bassler, K. E., 2007b, Martingale option pricing. *Physica A*, **380**, 351–356.
- Merton, R., 1973, Theory of rational option pricing. *Bell J. Econ.*, **4**, 141–183.
- McNeil, A. J., Frey, R. and Embrechts, P., 2005, *Quantitative Risk Management: Concepts, Techniques and Tools*, (Princeton: Princeton University Press).
- Montagna, G., Nicosini, O. and Moreni, N., 2002, A path integral way to option pricing. *Physica A*, **310**, 450–466.
- Shaw, W. T. and Schofield, M., 2012, A model of returns for the post-credit-crunch reality: hybrid Brownian motion with price feedback. *Quant. Finance*, DOI:10.1080/14697688.2011.642810.

Vellekoop, M. H. and Nieuwenhuis, J. W., 2007, On option pricing models in the presence of heavy tails. *Quant. Finance*, **7**, 563–573.

Wilk, G., and Włodarczyk, Z., 2000, Interpretation of the nonextensivity parameter q in some applications of Tsallis statistics and Lévy distributions. *Phys. Rev. Lett.*, **84**, 2770–2773.

Figure 1: PDF of Z_τ for increasing values of τ ; solid line corresponds to the analytical stationary solution, dashed ones to FCA, while bars in Panel (a) and symbols in Panel (b) refer to MC simulation of the process for maturity $\tau = 1$.

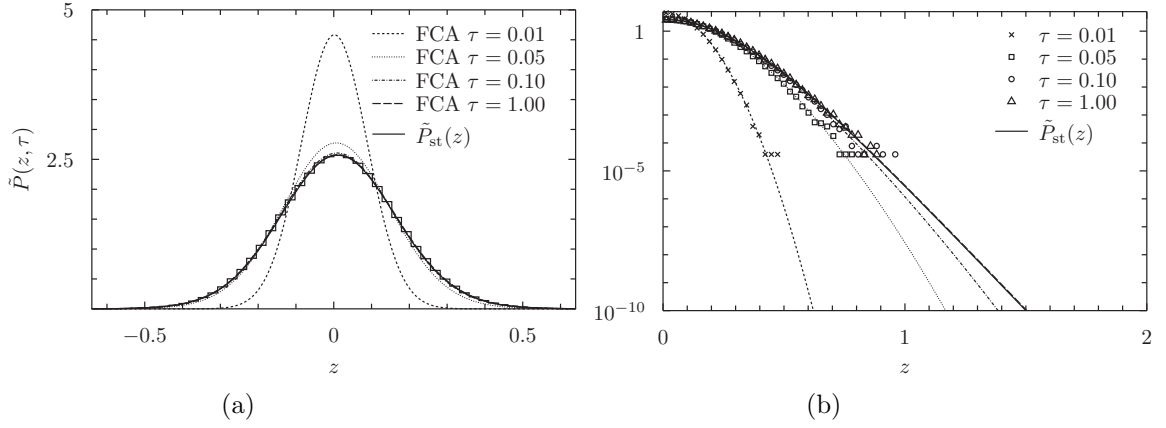

Figure 2: PDF of Z_τ for increasing values of τ ; lines correspond to FCA, while bars in Panel (a) and symbols in Panel (b) correspond to MC simulations.

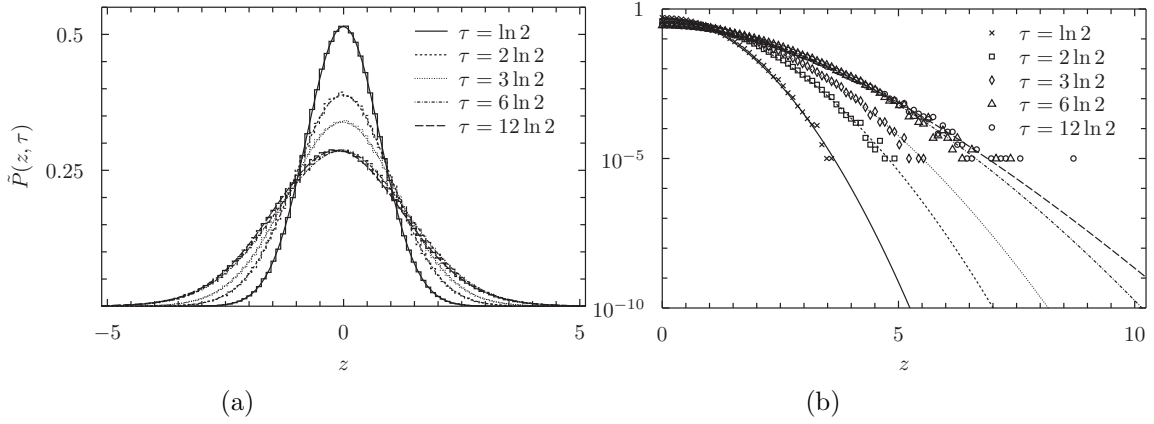

Figure 3: PDF of Z_τ at time $\tau = 1$ for $\sigma^2 = 1$ and $\varepsilon = 0.5, 1, 2$. Panel (a): comparison between analytical expressions (solid lines) and FCA (symbols); Panel (b): comparison between MC histograms (symbols) and FCA. Log-linear curves have been shifted for readability.

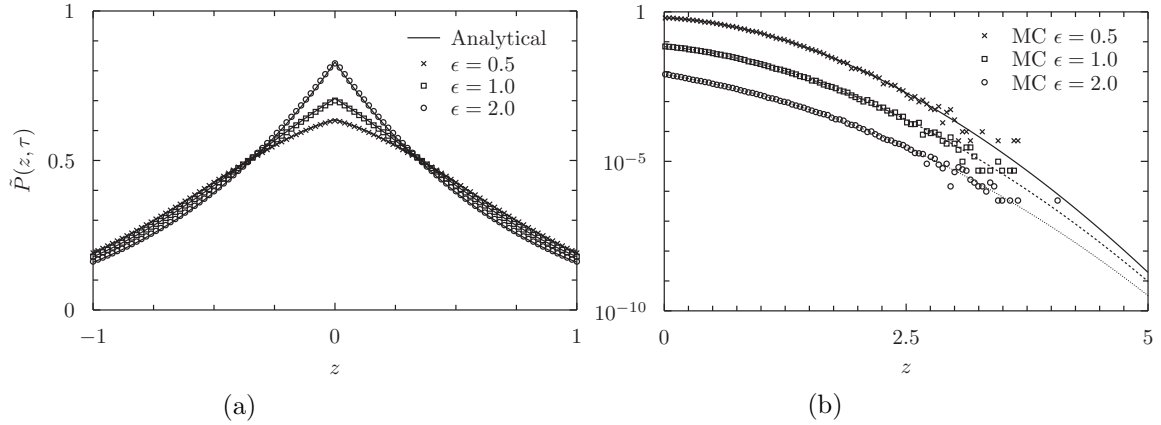

Figure 4: Piecewise diffusion: Risk neutral PDF of Z_τ at time $\tau = 1$ for $r = 0.03$, $\sigma^2 = 1$, and $\varepsilon = 0.5, 1, 2$. Comparison between Monte Carlo histograms (symbols) and FCA (dashed and dotted lines); in Panel (b) curves have been shifted for readability.

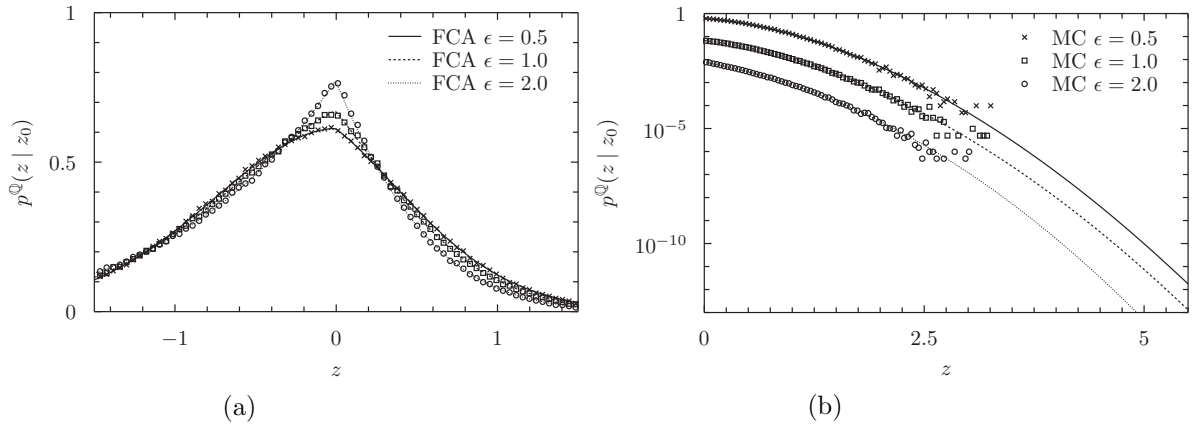

Figure 5: Piecewise diffusion: Bivariate risk neutral PDF of Z_τ and U_τ , and their corresponding marginals; $\varepsilon = 2$, $\sigma^2 = 1$, $t_0 = 0$, and $\tau = 1$. In Panel (b) comparison between Fast Convolution PDF of Z and MC histogram.

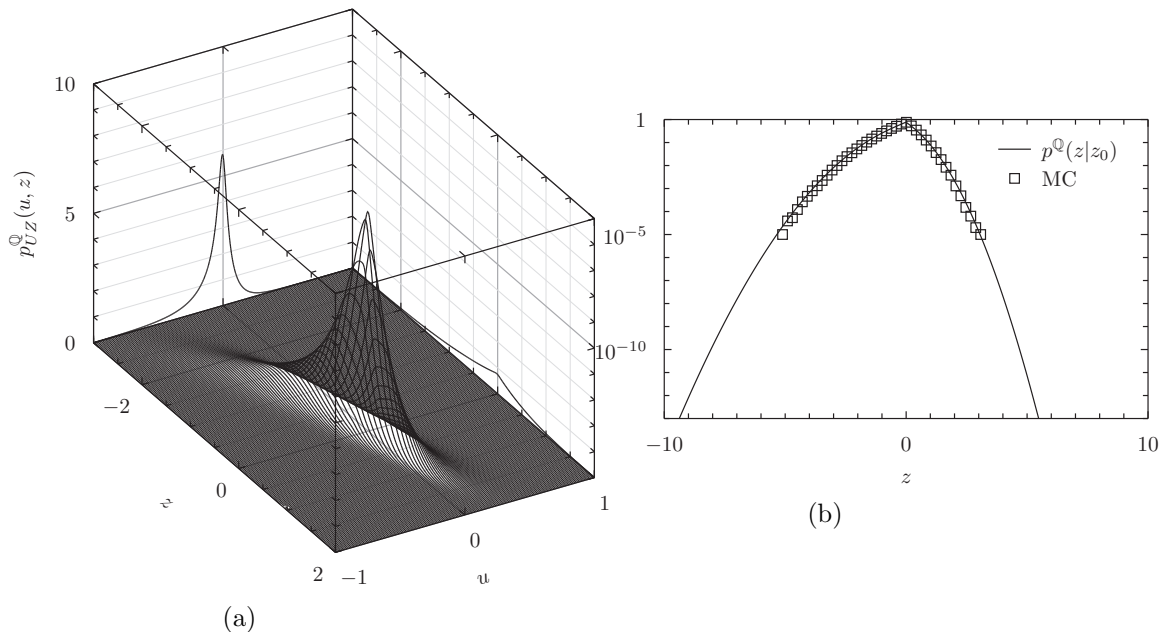

Figure 6: Vellekoop-Nieuwenhuis-Borland model: Bivariate risk neutral PDF of Z and U , and their corresponding marginals; $\alpha = 0.1$, $\Omega_0 = 0$, $t_0 = 0.2$, and $T = 0.7$. In Panel (b) plot of the fast convolution PDFs of Z and Ω and MC histogram of Z .

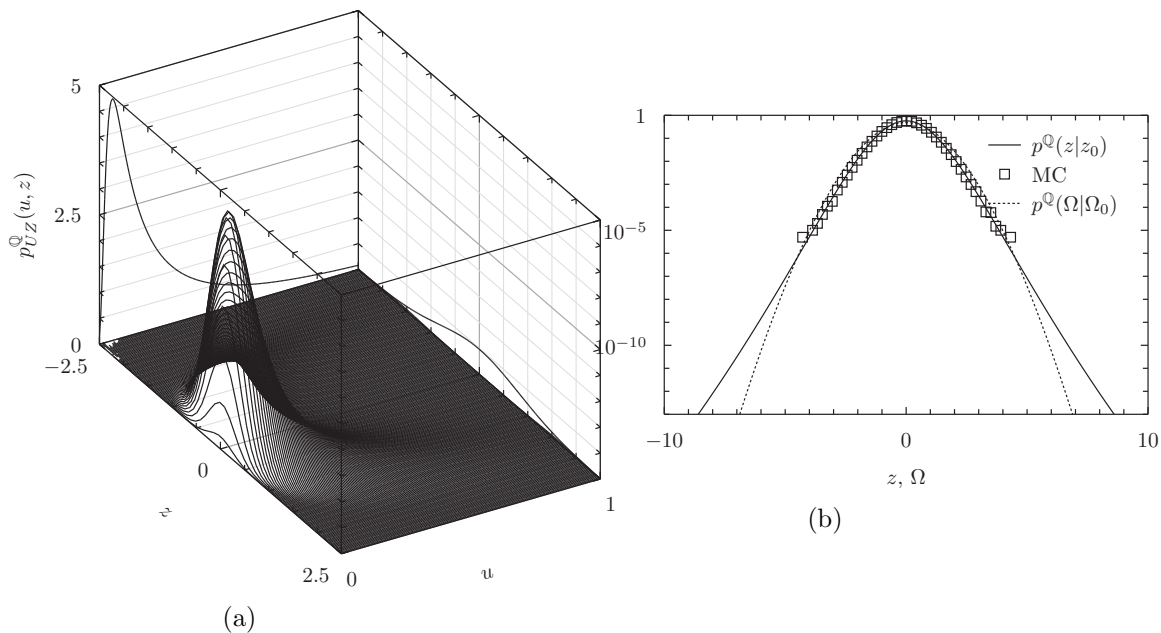

Figure 7: FCA implied volatility surfaces, $\alpha = 0.1$, $t_0 = 0.2$, Panel (a) $\Omega_0 = 0$, and Panel (b) $\Omega_0 = 0.5$; dashed lines for $T - t_0 = 0.5$ correspond to 95% Confidence Level from MC simulation.

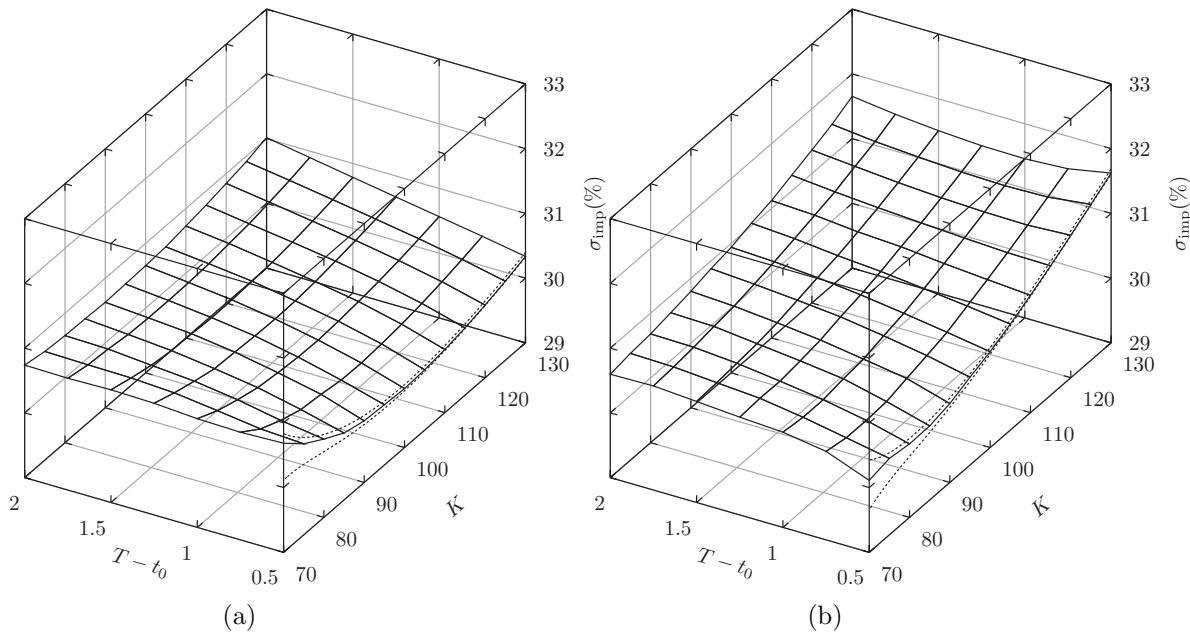
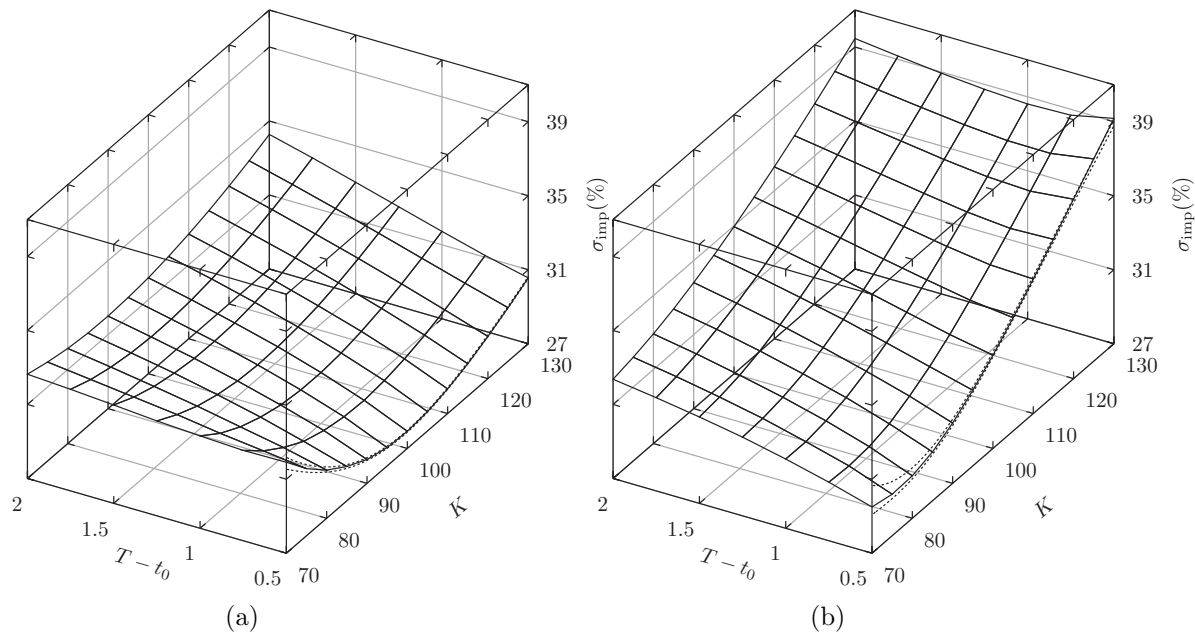

Figure 8: FCA implied volatility surfaces, $\alpha = 0.4$, $t_0 = 0.2$, Panel (a) $\Omega_0 = 0$, and Panel (b) $\Omega_0 = 0.5$; dashed lines for $T - t_0 = 0.5$ correspond to 95% Confidence Level from MC simulation.



2 Downside Risk in Currency Markets, Do Skewness and Tails Matter?

Sofia Cazzaniga

University of Lugano and Swiss Finance Institute

abstract

We study downside risk in currency markets by means of a proxy for the skewness of a high-minus-low currency portfolio, that measures the aggregate asymmetry of daily changes in spot exchange rates involved in a carry-trade strategy. We find that this factor is priced in the cross-section of forward discount sorted portfolios. The premium for the factor is about 6 basis points on a monthly basis for a sample period starting in January 1991 and ending in March 2011. Results are robust to bid ask spreads, subsample analysis and to different methodologies employed to estimate the market price of risk. Finally by means of Extreme Value Theory technique we construct a factor, which turns out to be related to the skewness proxy, tracking downside risk of deep-into-the-tails observations. We show that also this factor is priced in the cross section.

Keywords: Foreign Exchange, Carry Trade, Downside Risk, Skewness, EVT, Tail Index

*Special thanks go to Prof. Francesco Franzoni, Prof. Alberto Plazzi and Prof. Giovanni Barone-Adesi for their helpful advice and precious help. I also thank Prof. Angelo Ranaldo, Prof. Pasquale Della Corte and Matteo Borghi for their encouraging comments.

2.1 Introduction

Modeling foreign exchange risk has always been controversial for researchers: for a long time the attempt of overcoming the seminal result of Meese and Rogoff (1983), that proves exchange rates to be described by a “near random walk” process, have failed. Indeed, even if “our understanding of exchange rates has significantly improved, a number of challenges and open questions remain [...] enhanced by important events [...] such as the launch of the euro [...] and the large number of currency crises which occurred during the 90es” (Sarno and Taylor (2002)). Currency modeling is not a pure theoretical exercise for academics: changes in exchange rates are a significant determinant of returns on several different foreign investments⁸, thus even practitioners are interested in deepening the comprehension of the topic. Recently, though, the random walk benchmark has been successfully challenged, see for instance Rossi (2006) (instability of the relationship between exchange rates and fundamentals), Della Corte, Sarno and Tsiakas (2009) (Bayesian approach in a dynamic asset allocation setting), Della Corte, Sarno and Sestieri (2012) (predictive power of a measure of US external imbalances on bilateral US exchange rates) and Della Corte, Ramadorai and Sarno (2013) (cross-sectional predictive ability of currency volatility risk premium for exchange rate returns).

In this paper we will focus on the famous “currency carry trade strategy”⁹.

A naive carry trade strategy consists in investing in currencies of countries yielding high interest rates and funding this investment by borrowing currencies of countries with low interest rates. The strategy exploits violations of the Uncovered Interest Rate Parity (UIP), predicting zero returns on this kind of investments¹⁰. Several authors have proposed dif-

⁸Details on currency activity and volumes can be found in Galati, Melvin (2004), Galati, Heath and McGuire (2007) and Gyntelberg and Remolona (2007)

⁹Notice that because of the high profitability of CT banks created indexes tracking its performance, see for instance Barclay Capital Intelligent Carry, Credit Suisse FX Rolling Optimised Carry Index (ROCI), Citigroup Beta 1, Deutsche Bank Harvest, Jp Morgan Income FX.

¹⁰According to UIP the spread between the risk free interest rates of two countries should be wiped out by the depreciation of the highest or equivalently by the appreciation of the lowest interest rate

ferent explanations for UIP violation or equivalently for the abnormal carry trade returns: failure of rational expectation hypothesis and inefficiency of foreign exchange markets, Lewis (1989), Bacchetta and Wincoop (2010), Krasker (1980), Flood and Gaber (1980); lack of adequacy of traditional regression models, Chinn and Meredith (2004), Chinn and Meredith (2006), Baille and Bollerslev (2000), Maynard and Phillips (2001), Kirikos (2002) and time-varying risk premium, Engel (1996) (who provides a survey of this literature up to 1996), Frachot (1999), Backus Foresi and Telmer (2001), Brandt and Santa-Clara (2002), Alvarez, Atkeson and Kehoe (2010), Francis, Hasan and Hunter (2002), Hollifield and Yaron (2003), Fahri and Gabaix (2011), Verdelhan (2010), Fahri, Fraiberger, Gabaix, Rancièrè and Verdelhan (2009), Plantin and Shinn (2011).

Besides the articles previously mentioned, there is an extensive literature on currency returns anomalies, dealing with forward premium puzzle, excess carry trade returns, violations of uncovered interest rate parity (UIP) and extreme jumps movements. Two strands of this literature are relevant to this paper.

The first group deals with the investigation of priced risk factors in currency markets, built by means of macroeconomic or financial variables. McCurdy and Morgan (1991) develop an intertemporal asset pricing model in a conditional beta framework and use a world equity index as benchmark for the aggregate portfolio, finding it to be a source of systematic risk; Dahlquist and Bansal (2000) states that the risk premium is country-specific, as systematically connected to GNP per capita, average inflation rates, and inflation volatility. In a model with regime-dependent factor loadings, Christiansen, Rinaldo and Soderlind (2010) find that the abnormal currency carry trade returns can be explained by their exposure to the stock and bond market, and use foreign exchange volatility and liquidity for identifying different regimes. Lustig currency, i.e. “the expected foreign exchange gain from holding one currency rather than another - the expected exchange rate change - must be counterbalanced by the opportunity cost of holding funds in this currency rather than another - the interest rate differential” (Sarno and Taylor (2002)).

and Verdelhan (2007) study the cross section of currencies excess returns sorted on interest rate differential and argue that the risk premium emerges because of the correlation with consumption growth risk. Lustig, Roussanov and Verdelhan (2010) take an APT-like approach and identify two risk factors: the currency market returns available to a US investor (level factor) and a high minus low carry trade strategy (slope factor). Not only the slope factor is proved to be priced, but it also explains more than the 70% of the cross section of currency portfolios. Burnside, Eichenbaum and Rebelo (2011) and Burnside, Eichenbaum and Rebelo (2007) challenge some of previous results arguing that high Sharpe ratios cannot be a compensation for systematic risk (at least for developed countries), and affirm that they can be explained by market frictions (bid-ask spreads, price pressure). Again Burnside, Eichenbaum and Rebelo (2011) show that currency speculation strategies generate large payoffs on average, which are uncorrelated with traditional risk factors, and, in a microstructure approach framework, Burnside, Eichenbaum and Rebelo (2009) suggest that the forward premium may be due to adverse selection risk. In summary Burnside and his co-authors' baseline thesis aim at showing that "traditional factors are either uncorrelated with carry trade returns, i.e. they have zero betas, or the betas are much too small to rationalize the magnitude of the returns to carry trade", Burnside (2011). Some recent papers, though, give additional support to the risk based explanation of carry trade returns. Menkhoff, Sarno, Schmeling and Schrimpf (2012) show that excess returns to the carry trade are a compensation for aggregate time-varying volatility of exchange rates (Global FX Volatility) in the cross section of five currencies portfolio excess returns. They find liquidity risk to be priced as well, yet subsumed by global FX volatility innovations. Della Corte, Rime and Tsiakas (2013) introduce a factor, called global imbalance risk factor, that captures the exposure to the external imbalances of countries. Not only they prove the factor to be priced and to win the horse race with the other factors available in the literature, but they are able to provide a stringent economic rationale for its strong statistical power.

The second relevant strand of literature studies downside risk and crashes in currency markets.

A well known feature of currency markets is the presence of extreme events: currencies often experience big jumps. Consider for instance the 16% appreciation of the Yen against the USD from October 4 to October 10 1998, in coincidence with the crisis due to Russia and LTCM defaults; the appreciation of the Swiss franc and other currencies against the USD immediately after the “9/11” and the “Madrid attack” of March 2004 (Ranaldo and Söderlind (2010)); the big yen appreciations in 2007: of 7.7% on 16th of August and of 9% between the 7th and the 12th of November against the AUD (Melvin, Taylor (2009)); and in Autumn 2008: “up 60% against the AUD over 2 months, and up 30% against GBP (including 10% moves against both in five hours on the morning of October 24)” (Jordà and Taylor (2009)). In addition the “dramatic exchange rate movements occasionally happen without fundamental news announcements [...], analogously to what has been documented by Cutler, Poterba and Summers (1989) and Fair (2002)” (Brunnermeier Nagel and Pedersen (2008)) for other asset classes. These huge outliers suggest that linear volatility models may not be enough to measure risk in FX markets. Indeed return distributions exhibit non-gaussian features, such as asymmetry (measured via skewness) and non-linear return-volatility patterns, this latter property is extensively documented by Ranaldo and Söderlind (2010). Skewness of exchange returns series has already been investigated by several authors. It has been shown that carry trade returns and currencies exchange rate returns have skewness significantly different from zero at different sampling frequencies and time-horizons, and, since this skewness seems to be associated to occasional large and negative returns, it is often referred to as a measurable proxy of “downside risk” or of “crash risk”. In this framework Gyntelberg and Remolona (2007) consider measures of downside risk (VaR and expected shortfall) to be the most suitable to describe the risk of carry trade strategies. By calibrating their model on

currency option prices, Fahri, Fraiberger, Gabaix, Ranci re and Verdelhan (2009) are able to estimate disaster risk premia, and they show it accounts for 25% of carry trade excess returns. Again Fahri and Gabaix (2011) propose a theoretical model in which countries are differently exposed to disaster risk, modeled as a time-varying mean reverting process. Not only they provide explanation for the profitability of carry trade, but their model also reproduces several puzzling features of the currency market, such as the excess volatility of the exchange rate, the forward premium puzzle and the almost random walk exchange rate dynamics. By implementing carry trade within G10 currencies, Jurek (2008) documents that crash risk can explain excess returns of a currency speculative strategy, but only to the extent of 30-40%. Nozaki (2010) believes crashes reflect non-linear adjustments of currencies towards their fundamental values and thus sets up an hybrid strategy switching from naive carry trade to a fundamental strategy whenever the divergence of exchange rates from their fundamental values exceeds a threshold. The hybrid strategy is proved to be preferred by a utility maximizing investor, being short of crash risk. Downside risk in currency market has been documented once more by Brunnermeier Nagel and Pedersen (2008) for quarterly and weekly returns and later on for monthly returns including the crisis turmoil period by Anzuini and Fornari (2010). They interpret daily exchange rate skewness as evidence of crash risk for carry trade returns, they perform a cross sectional analysis and show that crash risk is driven by interest rate differential: currencies of countries having on average high interest rates with respect to US are associated to positive exchange rate returns skewness, that decreases towards negative values when moving to countries having on average low interest rates with respect to US. In addition they state that crash risk is driven by liquidity risk, in the sense that crashes are endogenous shocks due to unwinding of carry trade investments in periods of funding constraints. To conclude, downside risk and crash risk in the currency market is an highly up-to-date topic, as the recent thriving literature documents. The factor introduced by Della Corte, Rime and Tsiakas (2013), previously mentioned, has been

shown to be related to the sudden crashes experienced by CT returns. It is indeed able to explain abrupt drawdowns characterizing the currency markets and it has a clear interpretation in terms of macroeconomic fundamentals. Dobrynskaya (2012) and Lettau, Maggiori and Weber (2013) document a strong correlation between carry trade and global market risk during market downturns. They both provide systematic evidences that downside market risk is priced in the cross-section and in particular Lettau, Maggiori and Weber (2013) are able to reconcile the downside risk of currencies with that of other asset classes, i.e. equities, sovereign portfolios and commodities.

In this paper we investigate if an aggregate exchange rate skewness measure, tracking aggregate downside risk, is a source of systematic risk premium in the cross section of currencies excess returns. We start constructing a variable that measures the aggregate asymmetry in FX markets, $SKEW_M^{HML}$. It captures the skewness of daily exchange rate changes of currencies in the highest 25%-forward discount quantile minus the changes of those in the lowest within a month. We prove this factor to be cross-sectionally priced in a linear APT-like asset pricing framework. Therefore we provide, at least partially, rational explanation to the high profitability of currency carry trade strategies. High values of the skewness factor identify bad states of downside risk, owing to episodes of investment currencies drop and poor carry trade performance. Since low interest rate currencies positively co-move with the skewness factor, they play the role of a hedge by offering high returns in bad states for the skewness, low returns in good states. On the contrary high interest rate currencies are negatively correlated with the skewness factor, thus they return big abnormal profits to a US investor in a long position in low skewness realizations states (good states) and big losses when the skewness factor assumes high and positive values. As a consequence carry trade investors, having a long position in high and a short position in low interest rate currencies, are extremely exposed to the downside risk mimicked by $SKEW_M^{HML}$ factor. We furthermore document that our asymmetric skewness factor

is one of the driving sources of time-varying risk premium, though to a weaker extent than volatility. This last result is coherent with the competing paper of Rafferty (2011) who identifies a global currency skewness risk factor, à la Boyer, Mitton and Vorknik (2010), that turns out to be correlated to $SKEW_M^{HML}$, priced in the cross section of currencies excess returns. Similarly to ours, his skewness factor tracks the tendency of high interest rate investment currencies to depreciate sharply with respect to low interest rate funding currencies. Our paper differs from Rafferty (2011) both in the way the risk factor is computed, and in the analysis we perform on the role played by extremal observations in the cross section of currencies. Indeed in addition to $SKEW_M^{HML}$ factor, we identify a Tail factor, specifically shaped for collecting information of events in the tails of exchange rate returns when sharp depreciations of the investment currencies as a group relative to funding currencies as a group occur. The tail factor is identified by means of extreme value theory techniques (EVT). It is the high minus low portfolio in the cross section of currencies sorted according to the tail index (that represents the degree of fatness of tails) of the right tail of daily exchange returns. Observations in the right tail of daily exchange rate returns correspond to states of the world where foreign currency depreciates and US dollar appreciates, i.e. events extremely negative for a carry trade investor long high interest rate currencies and short USD. This kind of events definitely contributes to the well-known skewness pattern of daily exchange returns. Thus the tail factor analysis we perform and the results we present confirm again the important explanatory power of the third moment of daily exchange rate distribution for the profitability of carry trade strategies.

This paper is structured as follow. In Section 2.2 data, computation of excess returns and portfolio formation are described. Details on $SKEW_M^{HML}$ factor are reported in section 2.3. Section 2.4 deals with descriptive statistics and other empirical evidences on asymmetry properties of the cross section of daily exchange rate returns. Details on the estimation procedure and empirical results are provided in section 2.5, while

robustness checks can be found in section 2.6. In section 2.7 we describe the extreme value techniques we employ and the construction of the tail factor. Finally section 2.9 concludes.

2.2 Currency data and Portfolios Formation

We consider data on spot and forward exchange rates. Let s be the log spot exchange rate and f the 1-month log forward exchange rate, both in units of foreign currency per USD. In the empirical analysis we take the point of view of a US investor.

Data. The data are obtained from Datastream and cover the sample period from January 1991 to March 2011. The analysis is carried out at the monthly frequency (end of month series), though we need daily quotations to build the risk factors, as explained in details in the next section.

The sample we consider consists of the currencies of the following 47 countries : Australia, Austria, Belgium, Brazil, Bulgaria, Canada, Croatia, Cyprus, Czech republic, Denmark, Egypt, Euro area, Finland, France, Germany, Greece, Hong Kong, Hungary, India, Indonesia, Ireland, Israel, Italy, Japan, Kuwait, Malaysia, Mexico, Netherlands, New Zealand, Norway, Philippines, Poland, Portugal, Russia, Saudi Arabia, Singapore, Slovakia, Slovenia, South Africa, South Korea, Spain, Sweden, Switzerland, Taiwan, Thailand, Ukraine and United Kingdom.

Notice that a few of the currencies considered have partly pegged their exchange rate to the USD. From January 1999 several European currencies are substituted with the Euro. Following Lustig, Roussanov and Verdelhan (2010), we delete from the sample observations which reveals violations of the covered interest rate parity.¹¹

¹¹These violations are just a few: South Africa from July 1985 to August 1985 and Malaysia from end of August 1998 to June 2005.

Currencies and Portfolios Excess Returns. At the end of each month t , we rank currencies on the basis of their forward discount premium $f_t - s_t$, relative to the Dollar. The ranking is updated on a monthly basis. Notice that sorting on forward discount is equivalent to sorting according to interest rate differential with respect to USD. This is guaranteed by covered interest rate parity which states that $f_t - s_t \simeq i_t^* - i_t$, with i being the interest rate in US and i^* the one in a foreign currency. As a result, currencies are ranked from low interest rates (smallest forward discount), to high interest rates (highest forward discount).

We compute the monthly excess returns on buying the foreign currency k in the forward market and then selling it in the spot market, i.e. the mid quotes excess returns for holding the foreign currency k for one month, are computed as

$$rx_{(t+1)}^k = \begin{cases} (i_t^k - i_t) - \Delta s_{t+1}^k = f_t^k - s_{(t+1)}^k & \text{for a long position} \\ -f_t^k + s_{(t+1)}^k & \text{for a short position in the foreign currency.} \end{cases} \quad (37)$$

We then construct five portfolios of currencies sorted according to the forward discount in the previous month, whose excess returns are computed as the equally weighted average of their currencies excess returns. As expected, the total number of currencies in each portfolio varies through time, from a minimum of 2 currencies per portfolio, to a maximum of 7. A currency is included in the portfolio ranking only if it has spot and forward quotations both in the current and in the subsequent periods.

In addition to the five portfolios, we consider the ‘‘Dollar risk factor’’ (*DOL*) portfolio (see Lustig, Roussanov and Verdelhan (2010)), defined as the average return from borrowing USD and equally invest them in all available foreign currencies. *DOL* returns can be simply computed by averaging the five portfolios returns. Adding this factor to our empirical analysis is important as it tracks US dollar fluctuations against a broad basket of currencies, i.e. the dollar risk. This risk cannot be neglect since we take the point of view of a US investor.

Finally, we consider the carry trade portfolio HML_{FX} , defined as the return difference

between the fifth and the first portfolios. It is the return from a zero-cost strategy consisting in going short low interest rate currencies and going long those with high interest rates.

2.3 Risk Factors

Volatility proxy - Menkhoff, Sarno, Schmeling and Schrimpf (2012) proxy
Global FX Volatility in month t as

$$\sigma_t^{FX} = \frac{1}{\tau_t} \sum_{\tau \in \tau_t} \left[\sum_{k \in K_\tau} \left(\frac{|\Delta s_\tau^k|}{K_\tau} \right) \right], \quad (38)$$

where Δs_τ^k is the absolute daily log-return for each currency k on each day τ belonging to the month with indices $(t-1, t]$, τ_t denotes the total number of trading days in month t , K_τ denotes the number of available currencies on day τ . As Menkhoff, Sarno, Schmeling and Schrimpf (2012), in the following analysis we will consider the volatility innovations, residuals obtained after fitting an AR(1) model to σ_t^{FX} , denotes as $\Delta \sigma_t^{FX}$.

Skewness proxy. We construct a proxy for the downside risk of a *HML* currency strategy. Each month t , we sort the available currencies according to the forward discount in $(t-1)$ and we isolate those belonging to the quantile $[0.75, 1]$ (highest forward discount) and to the quantile $[0, 0.25]$ (lowest). On each day τ within that month, we then compute the daily spot exchange rate log-returns Δs_τ^{Kh} for each currency Kh in the highest quantile and average them over the currencies available, obtaining a time series vector H^τ . Analogously, we compute Δs_τ^{Kl} for each currency Kl in the lowest quantile and obtain L^τ by averaging over. Finally we define SKEW^{HML} in month t as the skewness over time of $(H^\tau - L^\tau)$ that is

$$\begin{aligned} \text{SKEW}_t^{HML} &= \text{Skewness}[H^\tau - L^\tau], \\ H^\tau &= \frac{1}{Nh_t} \sum_{k \in Kh_t} \Delta s_\tau^k, \quad L^\tau = \frac{1}{Nl_t} \sum_{k \in Kl_t} \Delta s_\tau^k, \end{aligned} \quad (39)$$

where **Skewness** denotes the standard moment-based measure¹². Nh_t and Nl_t denote respectively the numbers of available currencies in the highest and lowest quantile in month $(t - 1, t]$ and Δs_t^k the time series vector of absolute daily log-returns for currency k between the previous end month labeled $(t - 1)$ (excluded) and the end month t (included). Following Menkhoff, Sarno, Schmeling and Schrimpf (2012) we choose equal weights for all currencies to avoid the results to be driven by factors such as the volume of international trades.

As SKEW^{HML} is not a return factor, we build its factor-mimicking portfolio counterpart SKEW_M^{HML} , so that the results of our future analysis can be interpreted more easily. SKEW_M^{HML} can be obtained in two standard steps: firstly by regressing SKEW^{HML} on the excess returns of the five carry trade portfolios

$$\text{SKEW}_{t+1}^{HML} = \alpha + \sum_{i=1}^5 \beta_i rx_{t+1}^i + \varepsilon_{t+1} \quad (40)$$

in order to obtain $\hat{\beta}_1, \hat{\beta}_2, \hat{\beta}_3, \hat{\beta}_4$ and $\hat{\beta}_5$, and then computing

$$\text{SKEW}_{M,(t+1)}^{HML} = \sum_{i=1}^5 \hat{\beta}_i rx_{t+1}^i. \quad (41)$$

As it will be clear later, $\text{SKEW}_{M,t+1}^{HML}$ is an hedge against high interest rate currency depreciation, we therefore find that it loads negatively on the fifth portfolio ($\hat{\beta}_5 = -0.043$) and positively on the first ($\hat{\beta}_1 = 0.042$).

We plot DOL , $\Delta\sigma^{FX}$ and SKEW_M^{HML} in figure 9, panels (a), (b) and (c).

[Figure 9 about here]

2.4 Empirical Evidences

Descriptive Statistics. Table 1 provides descriptive statistics of portfolios excess log-returns considered in the empirical analysis.

¹²In analogy to Ghysels, Plazzi and Valkanov (2011) we adopt also “different measures of skewness”, but our results do not change substantially.

[Table 1 about here]

For each portfolio j , sorted monthly according to the forward discount in month $t - 1$, Panel I reports annualized mean returns and standard deviations (both in percentage points), skewness, kurtosis and Sharpe Ratios (SR) of monthly currency portfolio log-returns. Currencies are sorted in five portfolios according to the 20% quantiles of month $t - 1$ forward discount. Portfolio 1 contains currencies with the lowest forward discount, while Portfolio 5 contains those with the highest. **Average** coincides with the **DOL** portfolio, defined as the average return of a strategy borrowing money in US and investing in the foreign global money market; **High – minus – Low** is **HML_{FX}** carry trade strategy: long portfolio 5 and short portfolio 1. We compute also standard errors for the standard deviation, the skewness and the kurtosis by means of GMM of Hansen (1982), coupled with the delta method. We clearly notice that the unconditional mean and unconditional Sharpe Ratio increase from low to high forward discount currencies, while the unconditional skewness exhibits an overall decreasing trend. Seeking for positive excess returns, the most naive strategies consist in going long a bunch of the highest forward discount currencies and short a bunch of the lowest forward discount currencies ($rx^5 - rx^1$). This is the carry trade portfolio High-minus-Low that yields an average returns of 8.44% on annual basis, with corresponding Sharpe Ratio of 0.97. Notice that skewness is significant for portfolio 4 and 5 and the Sharpe ratio for portfolio 5, that is for high interest rate currencies and for the carry portfolio. No clear pattern is detected in the unconditional kurtosis, yet it is big and significant, suggesting that the distribution of the returns on the five portfolios are characterized by fat tails. Panel II reports descriptive statistics for daily exchange returns portfolios Δs^j , $j = 1, \dots, 5$, rebalanced every month according to the one-month forward discount. Currencies belonging to the high forward discount portfolio suffered on average a daily depreciation vis á vis the US \$ while the others registered in general an appreciation. Indeed, being k a generic foreign currency, a

positive $\Delta s_{t+1}^k = \log(S_{t+1}^k) - \log(S_t^k)$ denotes US dollar appreciation (i.e. currency k depreciation) between period t and $(t + 1)$; the opposite holds for a negative Δs_{t+1} . The unconditional cross section of standard deviation has an increasing behavior when moving from low to high forward discount currencies, while there is not a clear pattern for the unconditional kurtosis. Remarkably the skewness exhibits an overall increasing pattern: the cross section of unconditional skewness has an increasing trend in the forward discount. This is in agreement with the results of Brunnermeier Nagel and Pedersen (2008) who study a sample of eight developed currencies against the USD and document an almost linear cross-sectional relationship between the average interest rate differential (between the foreign country and the USD) and the average realized skewness of daily exchange rate returns within overlapping quarterly and weekly time periods. These results mean that currencies with similar levels of interest rates share both co-movement and exchange rate returns skewness sign. Moreover since skewness is not diversified away when currencies are aggregated into portfolios, as we show in table 1, and it increases conditionally on 1-M forward discount, we naturally wonder whether extreme currency movements are correlated across different countries, i.e. if the stylized facts we found are a systematic property of forward discount sorted portfolios. That is why we will investigate the common risk factor driving this correlation. Panel III reports the average frequency of portfolio switches. At each rebalancing day t and for each portfolio k , we count the number of currencies entering and exiting portfolio j with respect to time $(t - 1)$, we divide this number by the total number of currencies in that portfolio at time $(t - 1)$ and finally take the average of these frequencies over time. From the frequencies of table 1, we can see that currencies remains in the extreme portfolios for longer periods than in middle portfolios, before the switching. On average, a currency stays four months in portfolio 1, three months in portfolio 2, 3, 4 and 5 and five months in portfolio 6. Finally the average switching frequency across all portfolios is 34.21%, i.e. on average currencies switch portfolio every 3 months.

Cross Section of Empirical Skewness. As a first illustration of the stylized cross sectional relationship just briefly mentioned, we consider a time-series-coherent subsample of eleven developed currencies: Australian Dollar, Canadian Dollar, Denmark Krone, Japanese Yen, New Zealand Dollar, Norwegian Krone, Swedish Krone, Swiss Franc, Singapore Dollar and Euro. We choose these currencies since they have complete spot and forward exchange rate time series over the whole sample period, the only exception being the Euro, whose series starts in January 1999.

[Figure 10 about here]

Figure 10 plots the cross sectional relationship between average 1-month forward discount and respectively the unconditional ¹³ skewness of daily exchange rate movements Δs over the whole sample, panel (a), the average of Δs skewness computed within each quarter (non-overlapping periods), panel (b), and the average of Δs skewness within each month (non-overlapping periods), panel (c). We notice that in all three plots the skewness/average skewness is positive and high for carry trade investment currencies, i.e. AUD, NZD, GBP, CAD (positive forward discount or equivalently positive interest rate differential with US) and negative for funding currencies (negative forward discount or equivalently negative interest rate differential with US), say JPY, CHF. Ordinary Least Square fitting performance is rather high in all three cases, having an R^2 respectively of 66.09%, 86.15% and 81.37%.

[Figure 11 about here]

Figure 11 plots the time series of Japanese Yen/Australian dollar, panel (a) and of Swiss franc/New Zealand Dollar, panel (b), skewness of within a month daily exchange rate returns over the sample period considered. Clearly the funding currencies series

¹³I call this skewness unconditional in a time-series perspective. Notice that this skewness is conditional cross sectionally on the interest rate differential.

are shifted towards the bottom since the time-series mean of the skewness is negative, while the investment currencies are shifted upward. Consider for instance panel (a). The AUD and JPY series moves always in opposite directions. The same holds for the NZD and CHF, and for all couples of investment-funding currencies. These evidences suggest the existence of a time-varying risk of “directional” extreme daily exchange rate movements, i.e. towards dollar appreciation for investment currencies and towards dollar depreciation for funding currencies. Both these extreme movements are indeed adverse to a carry trade investor.

We now focus on low interest rate currencies. The distribution of their daily exchange returns is negatively skewed. This is illustrated in figure 12a where we depicted the kernel density estimation of Japanese Yen versus US Dollar daily exchange rate return. The lower panel is in semi-logarithmic scale, that allows a clearer investigation of the tails.

[Figure 12 about here]

Negative skewness means that negative Δs outcomes experience larger absolute value realizations than positive Δs outcomes, even if with low probability. Now, let’s consider a US investor shorting Japanese Yen, in order to gain from the interest rate differential between Japan-US. A longer left tail means that negative Δs events can be more extreme than the positive events, i.e. the distribution of Δs is skewed towards dollar depreciation (low currency appreciation). If we now turn our attention to high interest rate currencies, a US investor going long a foreign high interest rate currency (say, Australian Dollar) has to deal with positively skewed interest rate returns (see figure 12b), owing to episodes of large US \$ appreciation, i.e. foreign currencies depreciation.

It is worth pointing out that these results are not driven by the use of USD as a base currency: the empirical evidences are still there if we convert all exchange rates and we take the point of view of an investor set in another country. Therefore a naive

carry trade investor has to deal with asymmetric exchange rate returns distributions, skewed towards small probability events, yet extremely inauspicious in profitability terms. That is why currencies are said to “go down by the stairs and up by the elevator” (Plantin and Shinn (2011), Brunnermeier and Pedersen (2009)).

2.5 Empirical Analysis

Asset Pricing Model and Estimation. We apply the standard linear SDF approach to asset pricing, with usual Euler equation

$$\mathbb{E}[m_{t+1}rx_{(t+1)}^j] = 0, \quad (42)$$

where $rx_{(t+1)}^j$ is the excess return of currency j at time $(t+1)$, and m_t denotes the stochastic discount factor. Since asset pricing tests are performed on excess return levels and not on log excess returns, in analogy to Lustig, Roussanov and Verdelhan (2010) We compute the level excess returns for currency k as $rx_{(t+1)}^k = \frac{F_t^k - S_t^k}{S_t^k}$, with F and S being the forward and spot exchange rate levels. As usual, we adopt for m_t a parametrization linear in the risk factors h_t , i.e. $m_t = 1 - b'(h_t - \mu)$, with h the vector of factors, and μ the vector of their means. Eq. (42) with linearity assumption implies a beta pricing model

$$\mathbb{E}[rx^j] = \lambda' \beta^j \quad j = 1, \dots, 5 \quad (43)$$

where the expected excess returns are the product of the risky exposures β^j (the regression coefficients of portfolio excess returns on the factors) and the factor risk prices λ . We estimate the model by mapping the asset pricing model into GMM (Hansen (1982)), as illustrated by Cochrane (2005). We consider the following moment equations

$$\left\{ \begin{array}{l} \mathbb{E}[rx_t - \alpha - \beta h_t] = 0 \\ \mathbb{E}[(rx_t - \alpha - \beta' h_t) \otimes h_t] = 0 \\ \mathbb{E}[rx - \beta \lambda] = 0 \end{array} \right. \quad (43)$$

The GMM procedure produces the same point estimates as the two pass Fama-Macbeth regression method, allowing straight-away for the effect of generated regression, and for heteroskedasticity-robust inference. We use the two step GMM estimation with the efficient weighting matrix. In the first stage we start adopting the identity matrix. Standard errors are based on Newey and West (1987).

Results. In this section we want to empirically test whether the skewness factor $SKEW_M^{HML}$ helps the understanding of the cross section of FX excess returns.

Table 2 contains the results for the asset pricing test using the whole cross section of currencies, with DOL and $SKEW_M^{HML}$ as risk factors.

[Table 2 about here]

Panel II reports the time series betas loadings on the factors for the five forward discount-sorted portfolios. The loadings on the dollar risk factor are almost identical across all portfolios, this suggest that DOL captures the risk embedded in being a US investor that chooses to invest in foreign currencies. Instead the loadings on $SKEW_M^{HML}$ are positive for low interest rate (portfolio 1 and 2), negative for high interest rate currencies (portfolios 4 and 5) and we recognize a monotone pattern in β_{SKEW} . Panel I reports a negative and statistically significant skewness factor price of risk of -0.085% monthly. The negative sign is not surprising since high realizations of the skewness factor (positive values), owing to episodes of high interest rate depreciation and low interest rate appreciation, can be classified as bad states of the world characterized by low and negative Sharpe ratios. This means that those currencies that co-move positively with $SKEW^{HML}$, i.e. low interest rate currencies belonging to portfolios 1 and 2, return lower risk premia on average. They can be used to hedge

the risk tracked by the skewness factor, since in bad states of the world for the skewness their performance is on average positive. Because of this hedging properties, investors are not reluctant to accept lower returns on this type of investment. On the contrary investors require high risk premia on high interest rate currencies, that being positively correlated with the skewness factor, amplify profit and losses. Overall the spread in mean excess returns between high and low interest rate currencies is rationalized by the decreasing monotone behavior of the loadings on $SKEW^{HML}$. The high returns on carry trade strategies are thus at least partly explained: a carry trade investor, shorting low interest rate and investing in high interest rate currencies, loads positively on the skewness factor; in other words it bears the risk of downside, i.e. the risk of a sudden depreciation of the investment currency.

Having assessed that $SKEW_M^{HML}$ is priced in the cross-section of forward discount sorted portfolios, We now test if its informative content is subsumed by $\Delta\sigma_{FX}$. We therefore GMM-estimate the asset pricing model with the three risk factors DOL, $\Delta\sigma_{FX}$ and of $SKEW_M^{HML}$. The results for the whole sample period (January 1991-March 2011) are reported table 3.

[Table 3 about here]

Not surprisingly the volatility factor, being probably estimated with more accuracy run out the statistical significance of the skewness factor when the asset pricing test is performed on the whole sample. Yet the result changes when we consider two different subsamples identified by the introduction of the euro. Results can be found in tables 4 for the post euro and 5 for the pre-euro era.

[Tables 4 and 5 about here]

In both cases the skewness risk premium is negative and statistically significant (being around $\sim -0.6\%$ on a monthly basis) and the skewness betas loadings are decreasing

in the forward discount. Interestingly in the pre-euro sample the volatility risk factor is not significant while it co-exists with the skewness factor in the post-euro sample. Moreover the skewness price of risk is a little higher in absolute value in the pre-euro area. These empirical evidences might be driven by the Euro, whose introduction, seen as a choice of monetary stability, has decreased the perception of the risk of destabilizing currency crisis (i.e. downside risk tracked by SKEW_M^{HML}) and thus has allowed the volatility risk to acquire more power. We find even further support for this thesis if we consider the post-euro sample till July 2007, i.e. excluding the financial crisis. In this case $\lambda_{\text{skew}} = -0.0373$ (unreported table) that is definitely much smaller in absolute value than the $\lambda_{\text{skew}} = -0.076$ of the pre-euro sample, denoting a substantial decrease of downside risk.

We are aware of the fact that our results in the joint test of the three factors potentially suffer from the non-zero correlation between $\Delta\sigma_{FX}$ and SKEW_M^{HML} . A similar problem, yet much more intense, and in a different context than ours, has been illustrated by Barone-Adesi (1985) and brilliantly solved by means of the quadratic market model (i.e. by means of a reparametrization).

Relationship with Liquidity Proxies. Given previous results, it is now interesting to investigate the source of skewness in the FX market. Brunnermeier Nagel and Pedersen (2008) state that liquidity, in particular funding liquidity, helps our understanding of risk premia in foreign exchange markets, as they affirm that crashes, i.e. extreme inauspicious movements for carry trade that determine the skewness of the strategy, are endogenously generated by the unwinding of carry trade when funding liquidity tightens. Thus, I investigate the relationship of SKEW_M^{HML} with liquidity, by considering, as Menkhoff, Sarno, Schmeling and Schrimpf (2012), the Pastor-Stambaugh liquidity risk factor (Pastor and Stambaugh (2003)), the TED spread and a global aggregate measure of bid-ask spread, we call GLOBAL_{ba} as mea-

asures of liquidity/illiquidity. This latter is defined as

$$\Phi_t^{FX} = \frac{1}{\tau_t} \sum_{\tau \in \tau_t} \left[\sum_{k \in K_\tau} \left(\frac{\phi_\tau^k}{K_\tau} \right) \right], \quad (44)$$

with ϕ_τ^k the percentage bid-ask spread of currency k on day τ ; the other symbols has to be interpreted as in eq.(38).

We report the correlation of liquidity factors with $\Delta\sigma^{FX}$ and SKEW_M^{HML} in table 6, respectively Panel I and Panel II.

[Table 6 about here]

Overall we find that global foreign volatility innovations are positively correlated with innovations in TED spread. This is in agreement with finance theory: the sign of the illiquidity premium, if exists, should be negative, as an increase in illiquidity is a bad state of the world for the investor, who expect to earn a lower expected return. Coherently $\Delta\sigma^{FX}$ is negatively correlated with Pastor-Stambaugh liquidity risk measure. These results are consistent with those of Menkhoff, Sarno, Schmeling and Schrimpf (2012), and with the standard known fact that liquidity and volatility are correlated, though the moderate strength of the empirical correlations found.

The correlations are weaker when we compare liquidity-illiquidity measures with SKEW_M^{HML} . The correlations coefficients have reasonable signs but turn out to be much lower in absolute intensity.

Thus, our downside risk SKEW_M^{HML} does not seem to be considerably explained by standard liquidity proxies, or at least by those considered here; this result is coherent with Ang, Chen and Xing (2006), who study downside risk premium in the cross section of stock returns and find that it cannot be a reward for liquidity risk, among other hypothesis they consider. The investigation of the driving force behind skewness, like for instance time-varying risk aversion, are left for future research; though,

we cannot a-priori exclude the commonality of $SKEW_M^{HML}$ with other aspects of liquidity, which is known to be a complex and multi-faceted concept. $SKEW_M^{HML}$ might be, for instance, significantly correlated with the FX liquidity risk factors of Rinaldo, Mancini and Wrampelmeyer (2013).

Other authors proposed different theoretical explanations for the emergence of negative skewness in carry trade excess returns. For instance Plantin and Shinn (2011) believe in the mechanism of the bubble: in a game-theory setting they show that crowding in carry trades can endogenously generate skewness as a consequence of currency crashes. The greater the mass of speculators that enter the carry trade and pile up, the more likely are positive excess returns; but at the same time, the greater is the probability for a future unwind and a consequent crash. Ilut (2012), instead, proposes an alternative explanation for negative skewness of carry trade returns based on ambiguity averse agents. As they do not know the true stochastic process that rules high and low interest rate currency dynamics, agents attach larger weight to bad states (i.e. states of high interest rate currencies depreciation). This generates the negative skewness.

2.6 Robustness Check

In this section We investigate robustness issues of the model by performing asset pricing tests on returns of a smaller sample of currencies, that is only developed countries, by using Fama-Macbeth estimation procedure with betas estimate on a rolling window and by computing returns net of bid-ask spreads.

Developed Countries. We also perform the analysis on a smaller cross section containing only developed countries: Australia, Canada, Denmark, Euro area, Japan, New Zealand, Norway, Sweden, Switzerland and Great Britain. The sample we consider start in January 1991 and ends in March 2011. Results can be found in table 7

and are absolutely compatible with those of the larger cross section.

[Table 7 about here]

The market price of risk is now -0.037% monthly, smaller in absolute value than the -0.085% of table 2. This means that, as expected, on average developed countries are less exposed to downside risk, than emerging. At the same time, though, the significance of λ_{skew} for the subsample of developed countries ensures that our previous results are not driven by the higher riskiness of emerging countries.

Rolling window Fama-Macbeth We estimate once again the model via the two-step Fama and Macbeth (1973) procedure, see Cochrane (2005). We firstly run time series regression of portfolio excess returns on the factors DOL and SKEW_M^{HML} on a rolling window of 5 years (60 monthly observations) thus obtaining the times series of the factor loadings (β s) of each portfolio on each factor. In a second step for each t we run cross a sectional regression of the five portfolio excess returns on the β s. Eventually the prices of risk are obtained as sample averages of the second step estimates and their standard errors are computed from the sample variance-covariance matrix. We report the results we find in table 8. We plot also the rolling β s of the five portfolios in the figure below.

[Table 8 about here]

The price of risk for the skewness factor is negative and statistically significant; the skewness beta loading of the high interest rate portfolio is negative for every t and keeps below the others, as expected.

Bid-Ask Adjusted Returns. When bid-ask spreads are considered, we compute excess returns for long positions as $rx_{(t+1)}^k = f_t^{k,b} - s_{(t+1)}^{k,a}$ and for short positions as $rx_{(t+1)}^k = -f_t^{k,a} + s_{(t+1)}^{k,b}$. Returns net of bid-ask spreads for portfolio 1 (containing

funding currencies) are adjusted for short position transaction costs; the other four portfolios are adjusted for long position transaction costs. Notice that the specification of bid-ask spread we consider is likely to be quite conservative as it assumes 100% turnover each month in every currency. Moreover we underly that Reuters bid-ask spreads have been found to be on average two times bigger than the size of inter-dealer spreads (Lyons (2001)). Asset pricing test results are reported in table 9. We find a significant λ_{skew} of -0.053% per month.

[Table 9 about here]

2.7 Power Laws and Carry Trade

The skewness factor we introduced and investigated in the previous paragraphs can in principle suffer of two main drawbacks. Firstly, it is computed using only within-a-month returns and therefore can be noisy. Secondly, the interpretation of the skewness of a random variable is not unique even in case of unimodal distributions: for instance, the negative skewness can result both from the left tail being longer and the left tail being fatter, but we cannot discriminate between the two options if we do not know a priori the shape of the entire distribution. If, then, one of the two tails is longer and the other is fatter, the skewness sign is unpredictable, it might even turn out to be zero though the distribution is not symmetric. In this case no precise inference can be done. Finally no conclusions are possible in case of bi-modal distributions.

With these consideration in mind, in this section we take advantage of other instruments borrowed from Extreme Value Theory (EVT). We want indeed to investigate the events in the tails of exchange rate returns and their role in determining the asymmetry in daily exchange rate returns. The advantage is that Extreme Value Theory (EVT) does not require the knowledge of the exact distributional form.

Several papers have shown that distributions of many variables of interest in finance (in particular returns) exhibit deviations from Gaussianity, heavy tails and asymme-

try (Gabaix (2009), Embrechts et al. (1997), Huisman et al. (2003), . . .). In particular for the modeling of the tails of a return distribution people usually adopt power tail models, that is

$$\begin{cases} \Pr(r > x) \sim A_{\text{up}} x^{-\alpha_{\text{up}}} & x \rightarrow \infty \\ \Pr(r < -y) \sim A_{\text{down}} y^{-\alpha_{\text{down}}} & y \rightarrow -\infty \end{cases} \quad (45)$$

where r stands for the returns, $A_{\text{up}}, A_{\text{down}} > 0$ and $\alpha_{\text{up}}, \alpha_{\text{down}} > 0$ are called the tail index (or the tail exponent) for the right and left tail of the distribution of r respectively. The literature aimed at estimating the tail index for different financial series is huge and we are not going to resume it here, (we refer to Gabaix (2003), Gabaix (2009) and Ibragimov et al. (2013) works and their references), but on average researchers find that financial returns have a tail index $\alpha \in (2, 5)$. Tail indexes are usually estimated by means of EVT techniques, and, indeed, this is the approach we are going to adopt here as well. Appendix A contains information and references on the theory and on the estimation methodology we employ.

2.8 Tail Index Risk Factor

As a first caveat we point out that extreme returns are governed both by extreme innovations and by their dependence structure if they are not i.i.d. Moreover the asymptotic properties of the non-parametric estimators of the tail index are not clearly established (standard errors and estimates themselves can be biased), or better some alternative methodologies have been proposed but at the expense of introducing other parameters. Therefore the most common approach (see McNeil and Frey (2000)) consists in filtering univariate return series in order to get rid of autocorrelation and heteroskedasticity. In the following analysis we will consider residuals from fitting an AR(2)-GJR-GARCH(1,1) for each daily exchange return series.

In this section we want to assess whether daily exchange rate return distributions

differ in their upper and lower tails fatness, if a cross-sectional pattern is identifiable across different currencies and if it is relevant. In other words we want to investigate whether deep-into-the-tail events matter for risk premia of currency excess returns (as other authors argued, see Barro (2006), Gabaix (2012), ...) and whether connections with previous results we found with $SKEW_M^{HML}$ exist.

Given currency j , for T being the last day of each month, we estimate the tail index both for the up tail and the down tail on the previous 2000 daily exchange rate returns. As we need to have at least 2000 days of continuous daily exchange rate returns, we are able to have a sufficiently large number of currencies only from January 1999. Therefore in the following we will restrict the sample to January 1999-March 2011. From a preliminary cross-sectional analysis we notice that, as expected, the upside α of high interest rate currencies is on average lower than the downside α ; the vice-versa hold for low interest rate currencies. Figure 15a, 13b, 13c and 13d plot the time series of upside and downside tail index for a few currencies. In addition to this we notice that α^{UP} of high interest rate currencies are in general lower than those of low interest rate currencies, that is the up-tail of high interest rate currencies are fatter or, as expected, the probability of depreciation of the foreign currency with respect to the USD is higher for high interest rate currencies. The time series of upside α for the Australian Dollar, the New Zealand Dollar, the Swiss Franc and the Japanese Yen are plotted in figure 15e. On average the Australian Dollar and the New Zealand Dollar exchange rates, being high interest rate currencies, are characterized by lower tail index for the up tail.

With these considerations in mind, we use the time series of estimated up-tail beta for each currency and for each end of month, to dynamically sort monthly carry trade excess returns and we form five quantile equally weighted portfolios. Portfolio 1 contains currencies having low α^{UP} , that is on average high interest rate countries, while portfolio 5 contains currencies whose daily exchange rate return distributions have thinner up-tails. We do not claim that sorting currencies according to the decreasing

forward discount is one-to-one equivalent (but in reverse order) to sorting currencies according to α^{UP} , yet a relevant relationship exists: the equally weighted forward discount of the five portfolios sorted according to α^{UP} is decreasing: 2.38% on an annualized monthly basis for portfolio 1, 1.77% for portfolio 2, 1.28% for portfolio 3, 1.24% for portfolio 4 and 0.83% for portfolio 5.

We then consider the fifth-minus-one portfolio and we call it “Tail-risk factor”. Its time series is plotted in figure 15f. Its correlation with the $SKEW_M^{HML}$ is 23.10% on the sample period January 1999-March 2011, and of 26.54% when the crisis is excluded i.e. till July 2007. Though this correlation is not extremely high, yet it is relevant. Therefore, also thanks to the cross sectional properties of the α^{UP} series, we conjecture that the tail factor tracks the risk of extreme exchange rate movements highly adverse to a carry trade investors. We check our hypothesis with a standard cross sectional asset pricing test on the usual five carry trade portfolios sorted according to the forward discount. The linear asset pricing model is estimated once again via GMM, with moments equations given by eq. (43) and $h_t = \text{DOL, TAIL_factor}$. Results are presented in table 10. The market price of risk for the tail factor is statistically significant and equal to -1.7 basis points on a monthly horizon. Not surprisingly the tail factor play the role of an hedge: during bad times for a carry trade investor the tail factor is high and positive, as currencies that have high upside betas (on average low interest rate currencies) appreciates and those having low upside betas depreciates. Also the factor loadings behave as expected: low interest rate currencies (portfolio1) load positively on the tail factor, therefore play the role of an hedge against extreme adverse currency movements, while high interest rate currencies (portfolio 5) are riskier and indeed load negatively on the tail factor. Notice that the market price of risk is much lower than the ~ -6 basis points of $SKEW_M^{HML}$ over the same sample period, as the tail factor focus on adverse movements really deep-into-the tails. To check whether our last results are driven by the financial crisis, we perform the asset pricing test on

a sample ending in July 2007. Clearly from table 11 we deduce that the market price of risk is significant and of magnitude similar to the one of table 10.

Finally, we repeat the same analysis replacing the α^{UP} with α^{DOWN} , but all results break down. Carry traders care more at deep-into-the-tails depreciation of high interest rate currencies, rather than the appreciation of low interest rate currencies.

2.9 Conclusion

This article investigates the role of extreme exchange rates movements on the profitability of foreign currencies investment strategies. In particular we try to reconcile two strands of the literature, one seeking risk factors priced in the cross-section of currency excess returns portfolios sorted according to forward discount, and the other dealing with downside risk and exchange rate returns skewness/asymmetry.

The most recent results belonging to the first group of papers are those of Menkhoff, Sarno, Schmeling and Schrimpf (2012), who assessed the explanatory power of volatility in the cross section of currencies, with the introduction of a the Global FX volatility factor. This bright achievement stems from a well documented time-series empirical evidence (e.g. see Bhansali (2007)): carry trade strategies perform well when “market” volatility is low, vice-versa experience high losses in periods of uncertainty. We try to combine these results with empirical evidences on daily exchange rate returns skewness distribution (see Brunnermeier Nagel and Pedersen (2008)) by building a skewness based risk factor tracking downside risk in exchange rate returns, i.e. the asymmetries in daily exchange return distribution, not captured by volatility. We find that $\text{SKEW}_M^{\text{HML}}$ variable is one of the systematic risk factor priced in the cross section of currency excess returns. More in details, low interest rate currency returns positively co-move with the skewness factor, providing an hedge to this source of risk; the opposite hold for high interest rate currencies. This means that carry trade profitability is also driven by the exposure to $\text{SKEW}_M^{\text{HML}}$, interpreted as a time-varying

risk of downside. The results survive several robustness tests.

Finally we apply extreme value theory (EVT) to exploit information in the tails of return series. We construct a factor, which turns out to be related to the skewness proxy, tracking downside risk of deep-into-the-tail observations and we show that it is priced in the cross section of carry trade excess returns. We therefore confirm that asymmetry of exchange rate return distribution (we measured either with $SKEW_M^{HML}$ or with the Tail_factor) is one of the sources of carry trade time-varying risk premium, though to a lesser extent than volatility.

References

- Alvarez F., A. Atkenson and P. Kehoe, 2009, Time-Varying Risk, Interest Rates, and Exchange Rates in General Equilibrium, *Review of Economic Studies*, 76(3), 851-878, 07.
- Ang, A., J. Chen and X. Yuhang, 2006, Downside Risk, *The Review of Financial Studies*, 19(4), 1191-1239.
- Anzuini A., F. Fornari, Shocks, Crash Risk and Carry Trades, 2010, *Working Paper*.
- Bacchetta, P., E. van Wincoop, 2010, Infrequent Portfolio Decisions: A Solution to the Forward Discount Puzzle, *American Economic Review*, 100, 837-869, 2010.
- Backus, D K., S. Foresi and C. I. Telmer, 2001, Affine Term Structure Models and the Forward Premium Anomaly, *The Journal of Finance*, 56, 1, 279-304.
- Baille, R., T. Bollerslev, 2000, The Forward Premium Anomaly Is Not As Bad As You Think, *Journal of International Money and Finance*, 19: 417-488.
- Barone-Adesi G., 1985, Arbitrage Equilibrium with Skewed Asset Returns, *Journal of Financial and Quantitative Analysis*, 20 (3), 299-313.
- Barro R.J., 2006, Rare Disasters and Asset Markets in the Twentieth Century. *Quarterly Journal of Economics*, 121: 823-866.
- Beirlant, J., P. Vynckier and J. Teugels, 1996, Practical Analysis of Extreme Values, *University Press*, Leuven .
- Bhansali, V., Volatility and the Carry Trade, 2007, *Journal of Fixed Income*, 17(3), 72-84.
- Bowley, A. L., 1920, Elements of Statistics, *New York: Charles Scibner's Sons*.

- Boyer, B., T. Mitton and K. Vorknik, 2010, Expected Idiosyncratic Skewness, *The Review of Financial Studies*, 23,1, 169-202.
- Brandt, M. W., P. Santa-Clara, 2002, Simulated Likelihood Estimation of Diffusion with an Application to Exchange Rate Dynamics in Incomplete Markets, *Journal of Financial Economics* 63, 161-210.
- Breeden, D. T., M. R. Gibbons, and R. Litzenberger, 1989 Empirical Tests of the Consumption-Oriented CAPM, *Journal of Finance* 44, 231-262.
- Brunnermeier, M. K., S. Nagel and L. H. Pedersen, 2008, Carry Trade and Currency Crashes, *NBER Macroeconomics Annual*, 23, 313-347.
- Brunnermeier, M. K, L. H. Pedersen, 2009, Market Liquidity and Funding Liquidity, *Review of Financial Studies*, 22, 6, 2201-2238.
- Burnside, C., M. Eichenbaum, I. Kleshchelski, and S. Rebelo, 2011, Do Peso Problems Explain the Returns to Carry Trade?, *Review of Financial Studies*, 24(3), 853-91.
- Burnside, C., M. Eichenbaum, I. Kleshchelski, and S. Rebelo, 2007, The Returns to Currency Speculation in Emerging Markets, *American Economic Review* 97(2), May, 333-338.
- Burnside, C., M. Eichenbaum, and S. Rebelo, 2009, Understanding the Forward Premium Puzzle: A Microstructure Approach, *American Economic Journal: Macroeconomics*, 1(2), July, 127-54.
- Burnside, C., M. Eichenbaum and S. Rebelo, 2011, Do Peso Problem Explain the Returns to the Carry Trade?, *The Review of Financial Studies*, 24(3), 853-891.
- Burnside, C., 2011, "Carry Trade and Risk", in Jessica James, Ian W. Marsh and Lucio Sarno, eds., *Handbook of Exchange Rates*. Hoboken: John Wiley & Sons, 2012.

- Chinn, N. D., N. Meredith, 2004, Monetary Policy and Long-Horizon Uncovered Interest Parity, *IMF Staff Papers*, 51, 3.
- Chinn, N. D., N. Meredith, 2006, The Rehabilitation of Interest Rate Parity in the Floating Era, *Journal of International Money and Finance*, 25, 1, 7-21.
- Christiansen C., A. Rinaldo and P. Soderlind, 2010, The Time Varying Systematic Risk of Carry Trade Strategies, *Journal of Financial and Quantitative Analysis*, 46, 4, 1107-1125.
- Clauset, A., C. R. Shalizi and M. E. J. Newman, 2009, Power Law Distribution in Empirical Data, *SIAM Review* 51, 661-703.
- Cochrane, J., 2005, Asset Pricing, *Princeton University Press:NJ*.
- Cutler, D. M., J. M. Poterba, and L. H. Summers. 1989. What Moves Stock Prices?, *Working Paper, NBER, Cambridge, MA*, no. 2538.
- Dahlquist, M., R. Bansal, 2000, The Forward Premium Puzzle: Different Tales from Developed and Emerging Economies, *Journal of International Economics* 51, 115-144.
- Della Corte P., Sarno L. and Tsiakas, I., 2009, An Economic Evaluation of Empirical Exchange Rate Models, *The Review of Financial Studies*, 22, 9, 3491-3530.
- Della Corte P., Sarno L. and Sestieri G., 2012, The Predictive Information Content of External Imbalances for Exchange Rate Returns: How Much Is It Worth?, *Review of Economics and Statistics*, 94, 1, 100-115.
- Della Corte, P., Riddiough S. and Sarno L., 2013, Currency Premia and Global Imbalances, *Working Paper*.
- Della Corte, P., Ramadorai T. and Sarno L., 2013, Volatility Risk Premia and Exchange Rate Predictability, *Working Paper*.

- Dobrynskaya, V., 2012, Downside Market Risk of Carry Trades, *Working paper*.
- Embrechts, P., C. Kluppelberg and T. Mikosch, 1997, Modeling Extremal Events for Insurance and Finance, *Springer*, New York.
- Engel, C., 1996, The Forward Discount Anomaly and the Risk Premium: A Survey of Recent Evidence, *Journal of Empirical Finance* 3 (June): 123-92.
- Fahri, E., S. Fraiberger, X. Gabaix, R. Ranci ere and A. Verdelhan 2009, Crash Risk in Currency Markets, *NBER Working Paper* (June) 15062.
- Fahri, E., X. Gabaix, 2011, Rare Disasters and Exchange Rates, *Working Paper*, *Harvard University*.
- Fair, R. C., 2002, Events That Shook the Market, *Journal of Business* 75, 713-32.
- Fama, E., J. MacBeth, 1973, Risk, Return and Equilibrium: Empirical Tests, *Journal of Political Economy*, 81, 607-636.
- Flood, R., P. Garber, 1980, Market Fundamentals Versus Price Level Bubbles: The First Tests, *Journal of Political Economy*, 88: 745-770.
- Frachot, A., 1999, A Reexamination of the Uncovered Interest Rate Parity Hypothesis, *Journal of International Money and Finance*, 15, 3, 419-437.
- Francis, B., I. Hasan and D. Hunter, 2002, Emerging Markets Liberalization and the Impact of Uncovered Interest Rate Parity, *Journal of International Money and Finance*, 21, 931-956.
- Gabaix, X., G. Parameswaran, V. Plerou and E. Stanley, 2003, A Theory of Power Law Distributions in Financial Market Fluctuations, *Nature* 423, 267-270.
- Gabaix, X., 2009, Power Laws in Economics and Finance, *Annual Review of Economics* 1, 255-293.

- Gabaix, X., 2012, Variable Rare Disasters: An Exactly Solved Framework for Ten Puzzles in Macro-Finance, *Quarterly Journal of Economics*, 2012, 127(2), 645-700.
- Galati, G., A. Heath and P. McGuire, 2007, Evidence of Carry Trade Activity, BIS Quarterly Review, September.
- Galati, G., M. Melvin, 2004, Why has FX Trading Surged? Explaining the 2004 Triennial Survey, BIS Quarterly Review, December.
- Ghysels, E., A. Plazzi and R. Valkanov, 2011, Conditional Skewness of Stock Market Returns in Developed and Emerging Markets and its Economic Fundamentals, *SSRN Working Paper Series*.
- Gnedenko, B.V., 1943, Sur la Distribution Limite du Terme Maximum d' une Série Aléatoire, *Annals of Mathematics*, 44, 423-453.
- Gyntelberg, J., E. M. Remolona, 2007, Risk in Carry Trades: a Look at Target Currencies in Asia and the Pacific, *BIS Quarterly Review*, December.
- Hansen, L. P., 1982, Large Sample Properties of Generalized Method of Moments Estimators, *Econometrica* 50, 1029-1054.
- Hansen, L. P., R. Jagannathan, 1997, Assessing Specification Errors in Stochastic Discount Factor Models, *Journal of Finance* 52, 557-590.
- Hill, B. M. 1975, A simple general approach to inference about the tail of a distribution, *Annals of Statistics* 3, 1163-73.
- Hollifield B., A. Yaron, 2003, The Foreign Exchange Risk Premium: Real and Nominal Factors, *Working Paper*, University of Pennsylvania.
- Huisman R., K. Koedijk, C. Kool and F. Palm, 2002, Notes and Communications: the Tail-Fatness of FX Returns Reconsidered, *De Economist* 150, 3, 299-312.

- Ibragimov, M., R. Ibragimov, and P. Kattuman, 2013, Emerging Markets and Heavy Tails, *Journal of Banking and Finance*, 37(7): 2546-2559.
- Ilut, C., 2012, Ambiguity Aversion: Implications for the Uncovered Interest Rate Parity Puzzle, *American Economic Journal: Macroeconomics*, 4(3).
- Jordà, Ò., A. M. Taylor and M. Alan, 2009, The Carry Trade and Fundamentals: Nothing to Fear but FEER Itself, *Journal of International Economics*, forthcoming.
- Jurek, J. W., 2008, Crash-Neutral Currency Carry Trades, *Princeton University Working Paper*.
- Kirikos, D., 2002, Discrete Policy Interventions and Rational Forecast Errors in Foreign Exchange Markets: The Uncovered Interest Rate Parity Hypothesis Revisited, *International Journal of Finance and Economics*, 7, 327-338.
- Krasker, W., 1980, The Peso Problem in Testing the Efficiency of Forward Exchange Markets, *Journal of Monetary Economics*, 6 269:276.
- Lettau, M., M. Maggiori and M. Weber, 2012, Conditional risk Premia in Currency Markets and Other Asset Classes, *Journal of Financial Economics*, forthcoming.
- Lewis, K. K., 1989, Changing Beliefs and Systematic Rational Forecast Errors with Evidence from Foreign Exchange, *American Economic Review* 79(4): 621-636.
- Lustig, H., A. Verdelhan, 2007, The Cross Section of Foreign Currency Risk Premia and Consumption Growth Risk, *American Economic Review* 97, 89-117.
- Lustig, H., N. Roussanov and A. Verdelhan, 2010, Common Risk Factors in Currency Markets, *The Review of Financial Studies*, 24, 11, 3731-3777.
- Lyons, R. K., 2001, The Microstructure Approach to Exchange Rates, *M.I.T. Press*.

- Maynard, A., P. C. B. Phillips, 2001, Rethinking an Old Empirical Puzzle: Econometric Evidences on the Forward Discount Anomaly, *Journal of Applied Econometrics*, 16(6): 671-708.
- McCurdy, T. H., I. G. Morgan, 1991, Tests for a Systematic Risk Component in Deviations from Uncovered Interest Rate Parity, *Review of Economic Studies* 58(3), 587-602.
- McNeil, A. J., R. Frey, 2000. Estimation of Tail-Related Risk Measures for Heteroscedastic Financial Time Series: an Extreme Value Approach, *Journal of Empirical Finance* 7, 271-300.
- Meese, R. A., K. Rogoff, 1983, Empirical Exchange Rate Models of the Seventies: Do they fit Out of Sample?, *Journal of International Economics*, 14, 3-24.
- Melvin, M., M. P. Taylor, 2009, The crisis in the foreign exchange market, *Journal of International Money and Finance*, 28, 8, 1317-1330.
- Menkhoff, L., L. Sarno, M. Schmeling, A. Schrimpf, 2012, Carry Trades and Global Foreign Exchange Volatility, *Journal of Finance*, 67(2), 681-718.
- Newey, W. K., K. D. West, 1987, A Simple, Positive Semi-Definite, Heteroskedasticity and Autocorrelation Consistent Covariance Matrix, *Econometrica* 55, 703-708.
- Nozaki, M., 2010, Do Currency Fundamentals Matter for Currency Speculators?, *IMF Working Paper*, 10/39.
- Pastor, L., R. Stambaugh, 2003, Liquidity Risk and Expected Stock Returns, *Journal of Political Economy*, 111, 642-685.
- Plantin G., H. S. Shinn, 2011, Carry Trade and Speculative Dynamics, *Working Paper*.

- Rafferty, B., 2011, Currency Returns, Skewness and Crash Risk, *Working Paper*.
- Ranaldo, A., L. Mancini and J. Wrampelmeyer, 2013, Liquidity in the Foreign Exchange Market: Measurement, Commonality, and Risk Premiums, *Journal of Finance*, 68 (5), 1805-1841.
- Ranaldo, A., P. Sördelind, 2010, Safe Haven Currencies, *Review of Finance* 10, 385-407.
- Rossi, B., 2006, Are Exchange Rates Really Random Walks? Some Evidence Robust to Parameter Instability , *Macroeconomic Dynamics*, 10(1), 20-38.
- Sarno, L., M.P. Taylor, 2002, The Economics of Exchange Rates, *Cambridge University Press*.
- Shanken, J., 1992, On the Estimation of Beta Pricing Models, *Review of Financial Studies*, 5, 1-34.
- Sy, M., H. Tabarrei, 2010, Carry Trade and Return Crash Risk, *Working Paper*.
- Verdelhan A., 2010, A Habit-Based Explanation of the Exchange Rate Risk Premium, *The Journal of Finance*, 65, 1, 123-146.

Figure 9: **Risk Factors:** time-series plot of DOL, Global FX volatility innovations and of $SKEW_M^{HML}$, sample period January 1991-March 2011.

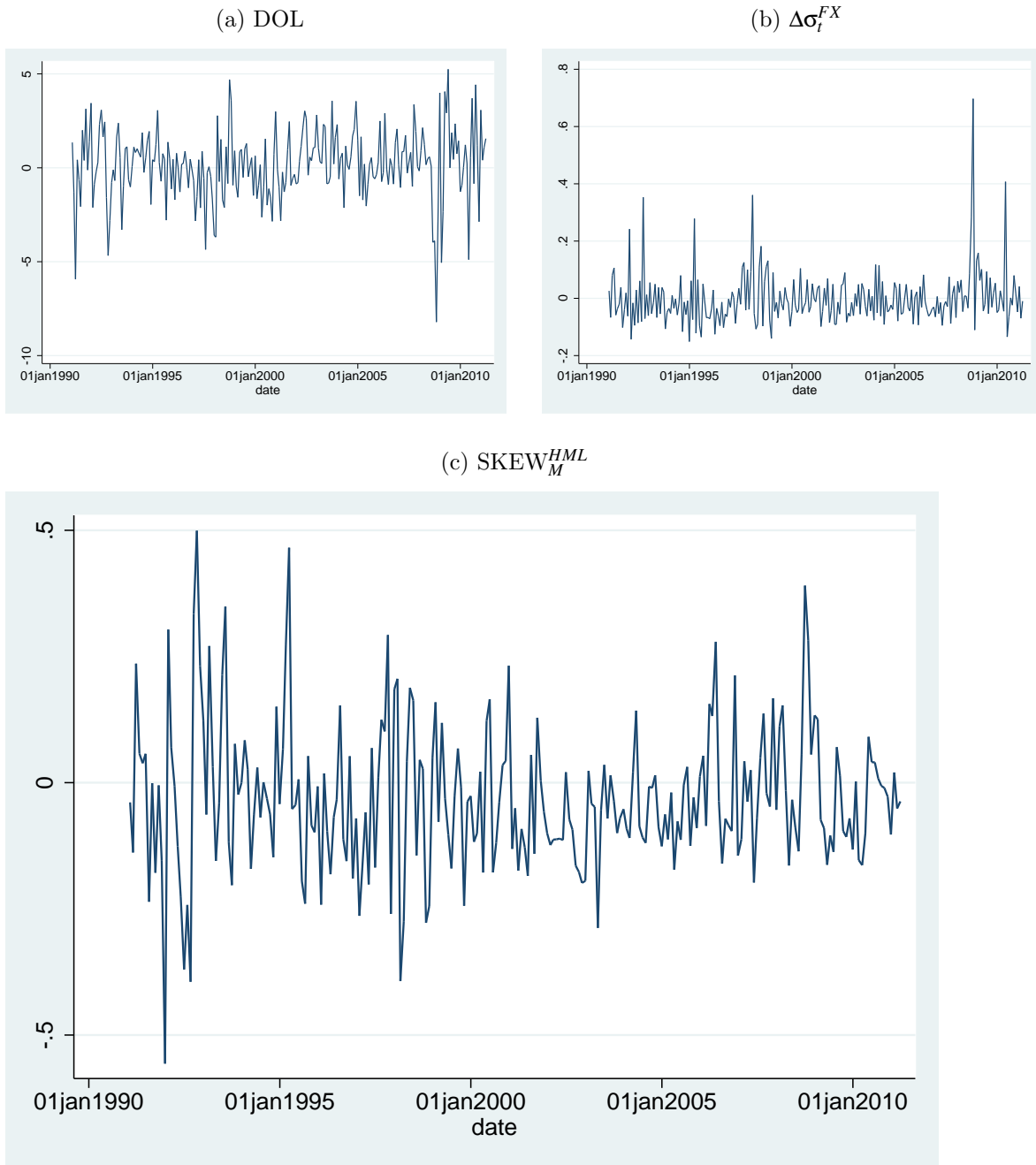

Figure 10: **Cross section of empirical skewness:** all sample ?? , average quarterly 13b and average monthly 13c of daily foreign exchange rate log-returns as a function of unconditional average 1-month forward discount. The sample period starts in January 1991 and ends in March 2011, except for the Euro, whose time series starts in January 1999. The currencies considered are the one depicted.

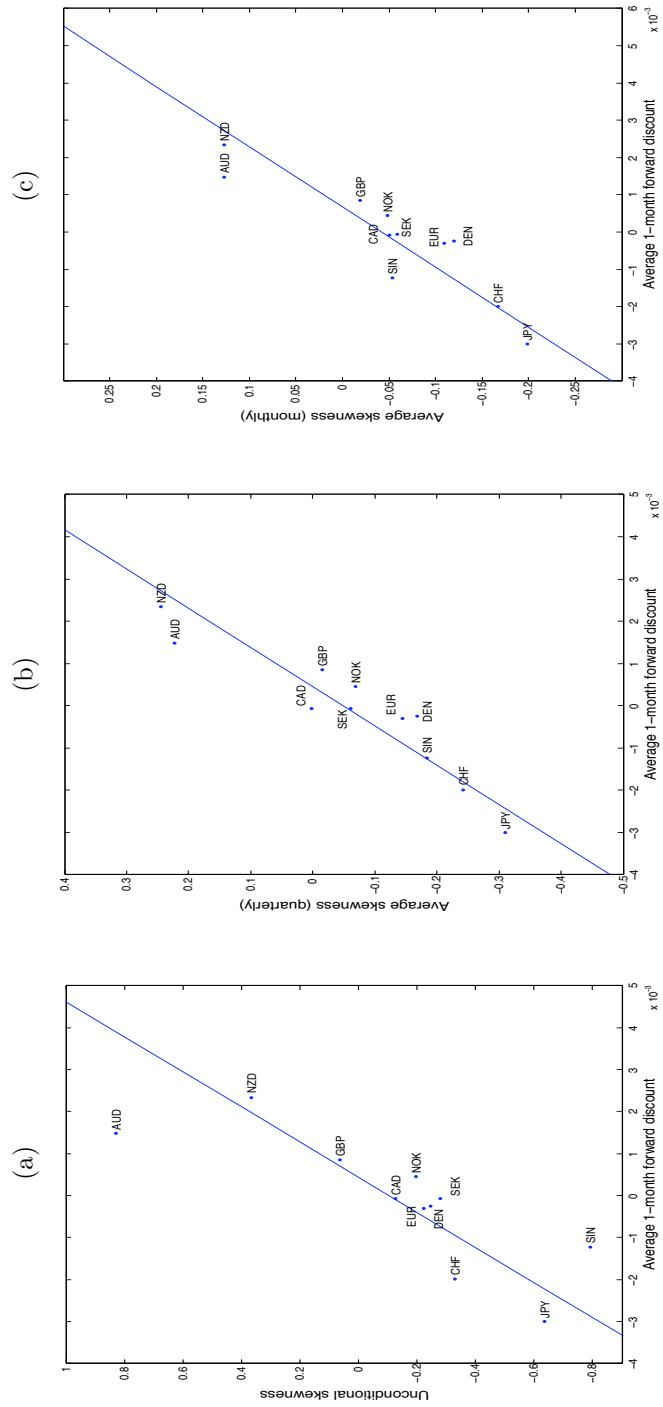
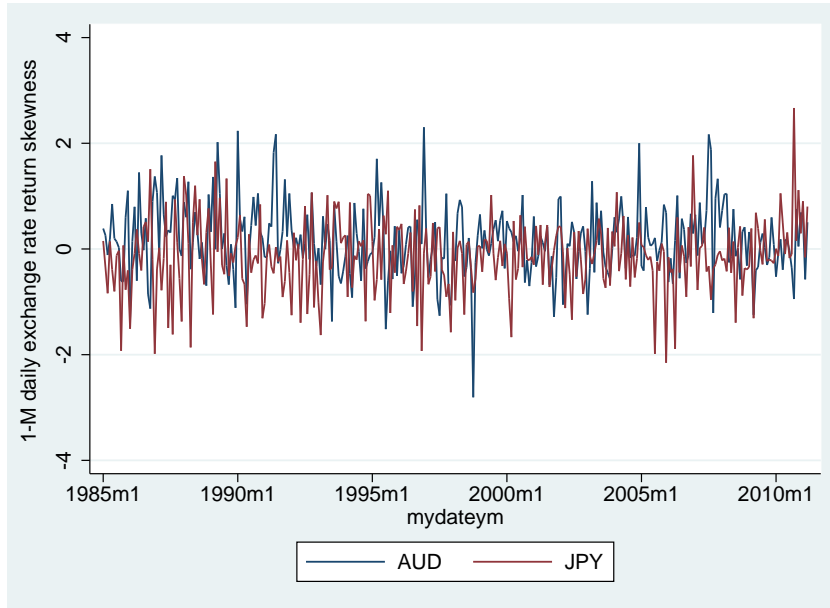
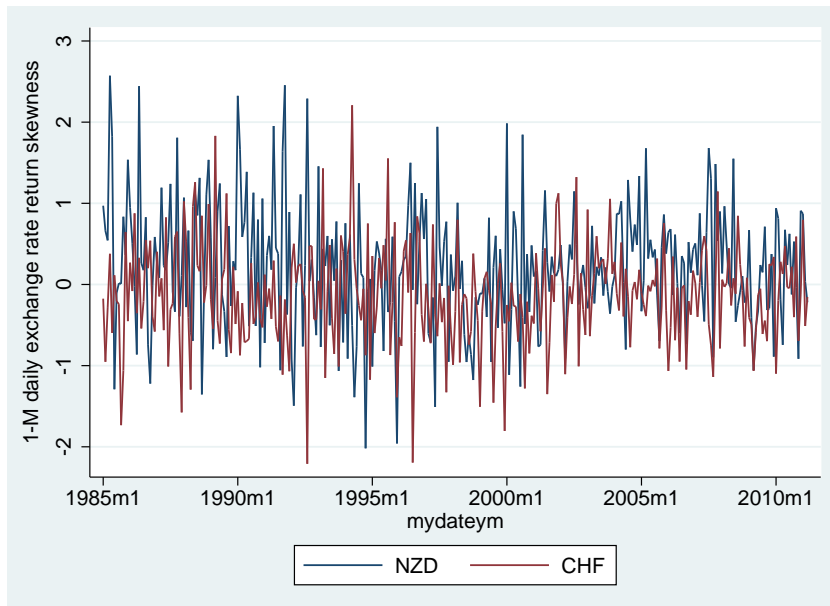

Figure 11: **Time series of 1-month daily exchange rate return skewness.** 13d deals with Japanese Yen (funding currency) and Australian dollar (investment currency), 13f with Swiss Franc (funding currency) and New Zealand dollar (investment currency).



(a)



(b)

Figure 12: **Kernel density estimation of daily exchange rate return density function of a low interest rate currency, i.e. Japanese Yen, panels 12a and of a high interest rate currency, i.e. Australian Dollar, panels 12b.** Lower panels plot the same density functions of the upper panels, though in semi-logarithmic scale.

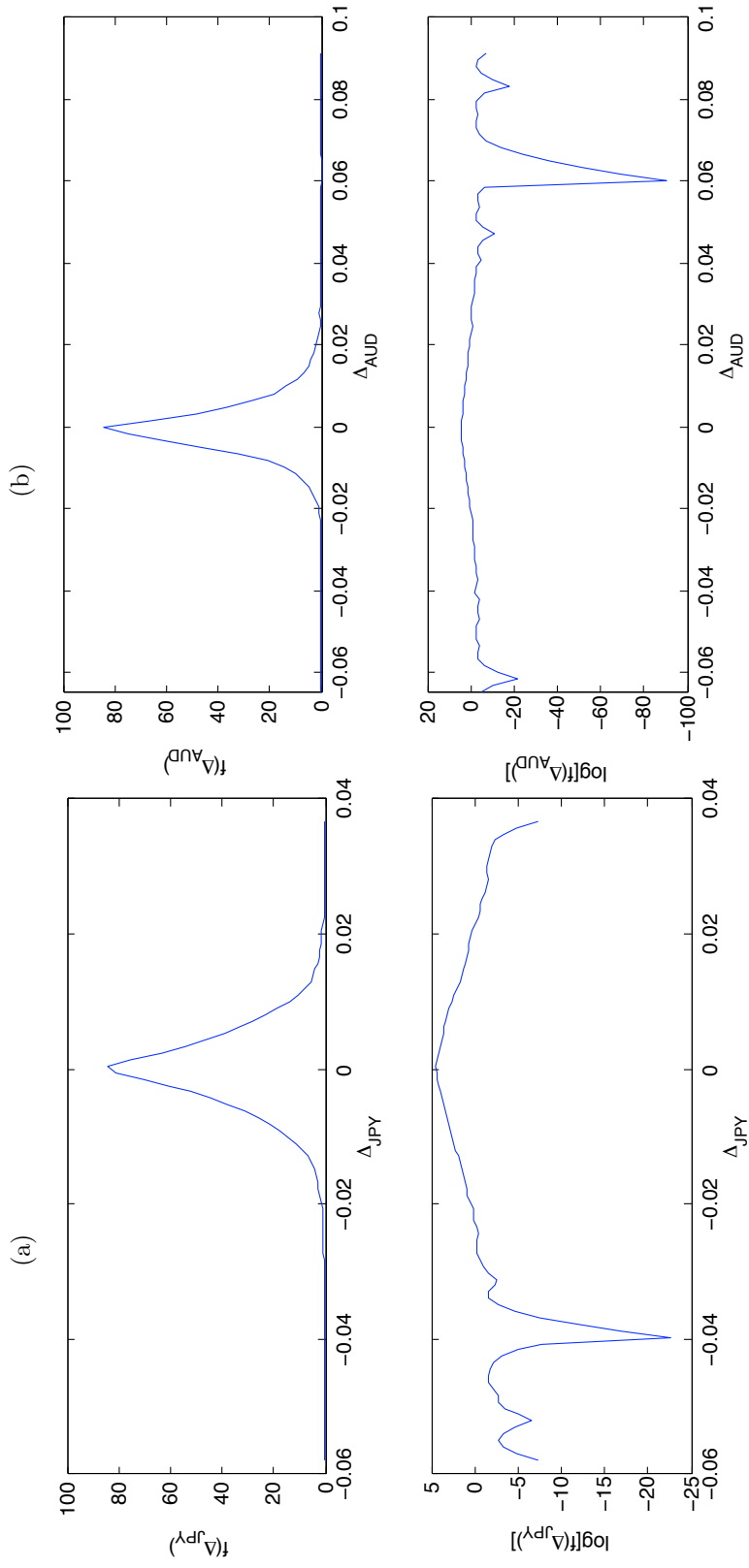
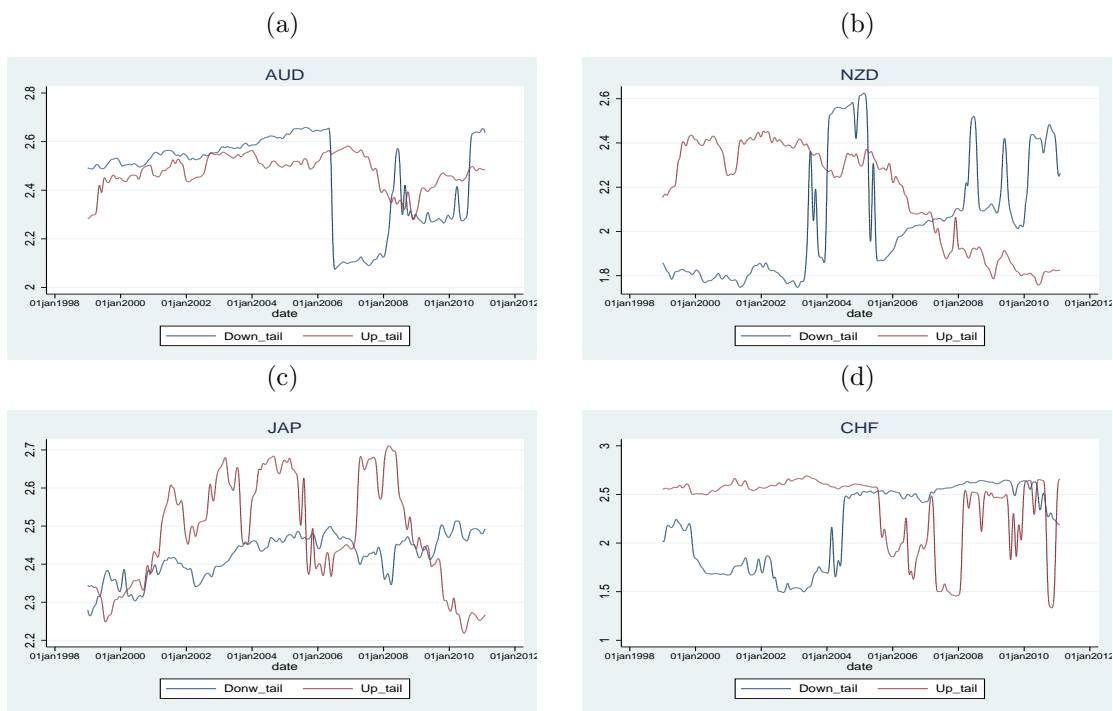
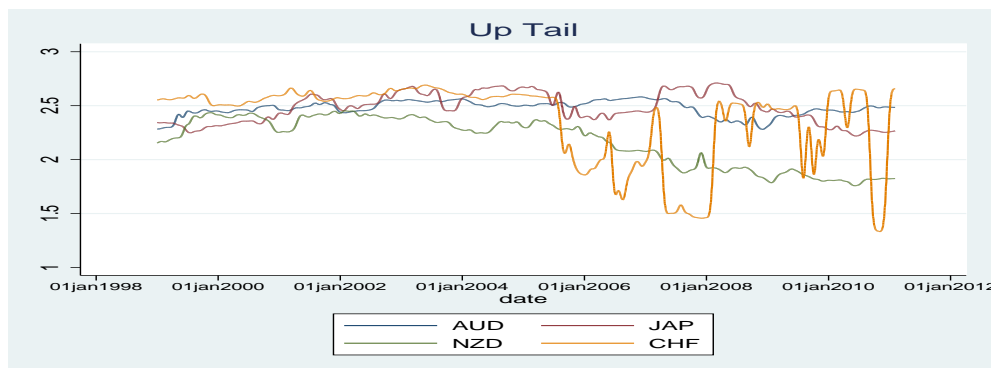

Figure 13: **Time-series related to the Tail Risk Factor.** Plots (a), (b), (c), (d), (e) reports up-tail and down-tail α s for a selected group of currencies. (f) depicts the time-series of the tail risk factor.



(e)



(f)

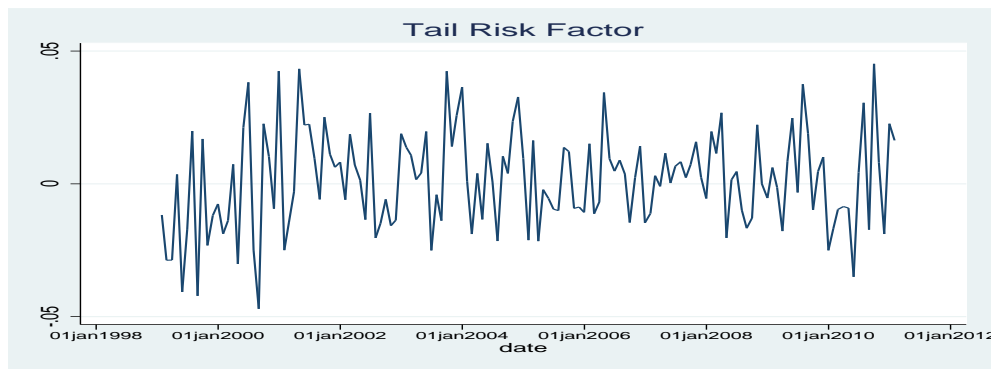

Table 1: **Descriptive Statistics:** for each portfolio j , sorted monthly on the forward discount at month $t - 1$, the DOL and the carry portfolio Panel I of this table reports annualized mean returns and standard deviations (both in percentage points), skewness, kurtosis and Sharpe Ratios (SR) of monthly currency portfolio log-returns. Panel II reports annualized mean returns and standard deviations (both in percentage points), skewness, kurtosis of the change in spot exchange rate Δs^j , $j = 1, \dots, 5$. Panel III shows the average switching frequency of currencies in each portfolio. Statistical significance has to be interpreted as $*p < 0.05$, $**p < 0.01$. The sample period starts in **January 1991** and ends in **March 2011** (243 monthly observations in Panel I, 5281 daily observations in Panel II). Point of view of a US investor.

Portfolio	1	2	3	4	5	Average	High minus Low
Panel I: log-excess returns							
Mean	-2.77	0.45	3.52	2.72	5.67	3.17	8.44
Std.dev.	6.54** (0.40)	6.27** (0.47)	7.53** (0.62)	7.91** (0.83)	9.71** (0.97)	6.54** (0.53)	8.71** (0.72)
Skew	-0.11 (0.23)	-0.11 (0.25)	-0.43 (0.27)	-1.00** (0.31)	-0.76* (0.35)	-0.53 (0.28)	-0.70** (0.19)
Kurt	3.93** (1.00)	4.29** (1.38)	4.93** (1.70)	6.69* (2.65)	6.12* (2.37)	4.75* (1.85)	4.32** (1.44)
SR	-0.42 (0.26)	0.07 (0.24)	0.46 (0.26)	0.34 (0.25)	0.58** (0.28)	0.27 (0.26)	0.97** (0.28)
Panel II: Spot change Δs^j							
Mean	-0.75	-0.76	-1.46	1.394	2.94	3.69	0.27
Std.dev.	5.83** (0.15)	5.95** (0.16)	7.13** (0.22)	7.26** (0.26)	8.27** (0.34)	8.11** (0.33)	5.71 (0.14)
Skew	-0.46** (0.15)	-0.52* (0.19)	-0.06 (0.20)	1.06 (0.65)	0.66** (0.23)	0.76** (0.18)	0.07 (0.15)
Kurt	7.79** (1.24)	9.01** (2.16)	9.43 * (2.18)	18.56 (11.23)	11.59** (2.87)	11.04** (2.72)	6.51** (1.15)
Panel III: Frequency							
Av. Switches (%)	22.88	35.17	37.91	40.03	35.06	34.21	

Table 2: **Cross-sectional test: DOL and SKEW_M^{HML}**. Panel I of this table reports cross-sectional pricing results for the factor model with the dollar risk factor (DOL) and the **skewness factor mimicking portfolio (SKEW_M^{HML})** on five carry trade portfolios. We estimate factor price of risk by means of two stage GMM. Standard errors (s.e.) of coefficient estimates are obtained according to Newey and West (1987). Panel II reports results coming from the other moment conditions, counterpart of time-series regressions of excess returns on a constant, the DOL, and the SKEW_M^{HML} factor. HAC standard errors (NeweyWest) are reported in parentheses. Statistical significance has to be interpreted as * $p < 0.05$, ** $p < 0.01$. The sample period is **January 1991 to March 2011**, 243 observations. Returns are monthly.

PANEL I			
	DOL	SKEW _M ^{HML}	
λ	0.300	-0.085**	
s.e.	(0.154)	(0.020)	
PANEL II			
Portfolio	α	DOL	SKEW ^{HML}
1	-0.182** (0.050)	0.930** (0.038)	6.017** (0.387)
2	0.050 (0.042)	0.941** (0.028)	4.743** (0.294)
3	0.146* (0.064)	1.064** (0.046)	0.289 (0.479)
4	-0.058 (0.063)	1.010** (0.050)	-4.288** (0.446)
5	0.070 (0.097)	1.054** (0.074)	-7.842** (0.707)

Table 3: **Cross-sectional test: DOL, VOL and SKEW_M^{HML}**. Panel I of this table reports cross-sectional pricing results for the factor model with the dollar risk factor (DOL) and the **skewness factor mimicking portfolio (SKEW_M^{HML})** and the global FX volatility innovations (VOL) on five carry trade portfolios. We estimate factor price of risk by means of two stage GMM. Standard errors (s.e.) of coefficient estimates are obtained according to Newey and West (1987). Panel II reports results for the other moment conditions, counterpart of time-series regressions of excess returns on a constant, the DOL, the SKEW_M^{HML} factor and VOL. HAC standard errors (NeweyWest) are reported in parentheses. Statistical significance has to be interpreted as * $p < 0.05$, ** $p < 0.01$. The sample period is **January 1991 to March 2011**, 243 observations. Returns are monthly.

PANEL I				
	DOL	SKEW _M ^{HML}	VOL	
λ	0.214	0.104	-0.216	
s.e.	(0.143)	(0.079)	(0.117)	

PANEL II				
Portfolio	α	DOL	SKEW ^{HML}	VOL
1	-0.366** (0.052)	0.941** (0.037)	5.809** (0.390)	4.576** (0.433)
2	-0.094* (0.042)	0.929** (0.027)	4.959** (0.310)	2.077** (0.326)
3	0.137* (0.061)	1.076** (0.049)	0.069 (0.474)	1.066 (0.915)
4	0.072 (0.060)	1.012** (0.045)	-4.320** (0.464)	-2.536 ** (0.864)
5	0.309** (0.092)	1.043** (0.070)	-7.635** (0.717)	-5.713 ** (1.458)

Table 4: **Post Euro Era.** Panel I of this table reports cross-sectional pricing results for the factor model with the dollar risk factor (DOL) and the **skewness factor mimicking portfolio (SKEW_M^{HML})** and the global FX volatility innovations (VOL) on five carry trade portfolios. We estimate factor price of risk by means of two stage GMM. Standard errors (s.e.) of coefficient estimates are obtained according to Newey and West (1987). Panel II reports results for the other moment conditions, counterpart of time-series regressions of excess returns on a constant, the DOL, the SKEW_M^{HML} factor and VOL. HAC standard errors (NeweyWest) are reported in parentheses. Statistical significance has to be interpreted as * $p < 0.05$, ** $p < 0.01$. The sample period is **January 1999 to March 2011**, 147 observations. Returns are monthly.

PANEL I				
	DOL	SKEW _M ^{HML}	VOL	
λ	0.312	-0.060***	-0.124**	
s.e.	(0.201)	(0.015)	(0.045)	

PANEL II				
Portfolio	α	DOL	SKEW ^{HML}	VOL
1	-0.249*** (0.0738)	0.896*** (0.0451)	5.683*** (0.680)	1.174* (0.669)
2	0.0725 (0.0517)	0.936*** (0.0370)	4.978*** (0.535)	-1.242*** (0.556)
3	0.129** (0.0573)	1.162*** (0.0348)	0.774 (0.565)	0.640 (0.864)
4	-0.184*** (0.0542)	1.069*** (0.0433)	-3.789*** (0.589)	-0.499 (0.619)
5	0.268*** (0.0853)	0.935*** (0.0540)	-8.467*** (0.794)	-0.177 (0.992)

Table 5: **Pre Euro Era.** Panel I of this table reports cross-sectional pricing results for the factor model with the dollar risk factor (DOL) and the **skewness factor mimicking portfolio** (SKEW_M^{HML}) and the global FX volatility innovations (VOL) on five carry trade portfolios. We estimate factor price of risk by means of two stage GMM. Standard errors (s.e.) of coefficient estimates are obtained according to Newey and West (1987). Panel II reports results for the other moment conditions, counterpart of time-series regressions of excess returns on a constant,, the DOL, the SKEW_M^{HML} factor and VOL. HAC standard errors (NeweyWest) are reported in parentheses. Statistical significance has to be interpreted as * $p < 0.05$, ** $p < 0.01$. The sample period is **January 1991 to December 1998**, 96 observations. Returns are monthly.

PANEL I				
	DOL	SKEW_M^{HML}	VOL	
λ	-0.066	-0.076**	0.055	
s.e.	(0.207)	(0.035)	(0.030)	

PANEL II				
Portfolio	α	DOL	SKEW^{HML}	VOL
1	-0.199** (0.064)	1.039** (0.045)	6.241** (0.396)	5.069** (0.614)
2	-0.065 (0.072)	0.909** (0.043)	4.859** (0.358)	2.992** (0.545)
3	0.155 (0.128)	0.907** (0.096)	-1.021 (0.575)	1.458 (1.339)
4	0.228* (0.090)	0.905** (0.075)	-5.196** (0.604)	-2.147 (1.558)
5	-0.072 (0.153)	1.237** (0.134)	-6.169** (0.907)	-7.948** (2.533)

Table 6: **Correlation between factors and liquidity/illiquidity proxies.** Correlation coefficients of $\Delta\sigma_{FX}$, TED spread, innovations in GLOBAL_ba and Pastor-Stambaugh liquidity measure (Panel I) and $SKEW_M^{HML}$, TED spread, innovations in GLOBAL_ba and Pastor-Stambaugh liquidity measure (Panel II). The sample period is **January 1991-March 2011** (243 monthly observations).

Panel I				
	$\Delta\sigma_{FX}$	BID-ASK	TED	PS
$\Delta\sigma_{FX}$	1			
BID-ASK	0.1623	1		
TED	0.3266	0.0783	1	
PS	-0.2214	-0.0781	-0.2332	1

Panel II				
	$SKEW_M^{HML}$	BID-ASK	TED	PS
$SKEW_M^{HML}$	1			
BID-ASK	-0.0169	1		
TED	0.2446	0.0783	1	
PS	-0.1314	-0.0781	-0.2332	1

Table 7: **Robustness I: developed countries.** Panel I of this table reports cross-sectional pricing results for the factor model with the dollar risk factor (DOL) and the **skewness factor mimicking portfolio (SKEW_M^{HML})** on five carry trade portfolios, when only **developed countries** are considered. We estimate factor price of risk by means of two stage GMM. Standard errors (s.e.) of coefficient estimates are obtained according to Newey and West (1987). Panel II reports results for the other moment conditions, counterpart of time-series regressions of excess returns on a constant, the DOL, and the SKEW_M^{HML} factor. HAC standard errors (NeweyWest) are reported in parentheses. Statistical significance has to be interpreted as * $p < 0.05$, ** $p < 0.01$. The sample period is **January 1991-March 2011** (243 monthly observations).

PANEL I			
	DOL	SKEW _M ^{HML}	
λ	0.169	-0.037*	
s.e.	(0.151)	(0.015)	

PANEL II			
Portfolio	α	DOL	SKEW ^{HML}
1	-0.000 (0.114)	1.122** (0.088)	7.768** (0.873)
2	-0.053 (0.088)	1.160** (0.093)	5.940** (0.854)
3	-0.011 (0.105)	1.247** (0.057)	0.814 (1.016)
4	0.000 (0.115)	1.151** (0.101)	-1.750 (1.084)
5	0.005 (0.113)	1.424** (0.086)	-3.398** (1.169)

Table 8: **Robustness II: Fama-Macbeth regression.** Panel I reports cross-sectional pricing results for the factor model with the dollar risk factor (DOL) and the **skewness factor mimicking portfolio** ($\text{SKEW}_M^{\text{HML}}$) on five carry trade portfolios, when the prices of risk are estimated by means of **Fama and Macbeth (1973)** procedure, and factor loadings estimated on a **rolling** basis (plotted on the figure below). Statistical significance has to be interpreted as $*p < 0.05$, $**p < 0.01$. The sample period is **January 1991 to March 2011**, 243 observations. Returns are monthly.

PANEL I		
	DOL	$\text{SKEW}_M^{\text{HML}}$
λ	0.131	-0.049**
s.e.	(0.140)	(0.010)

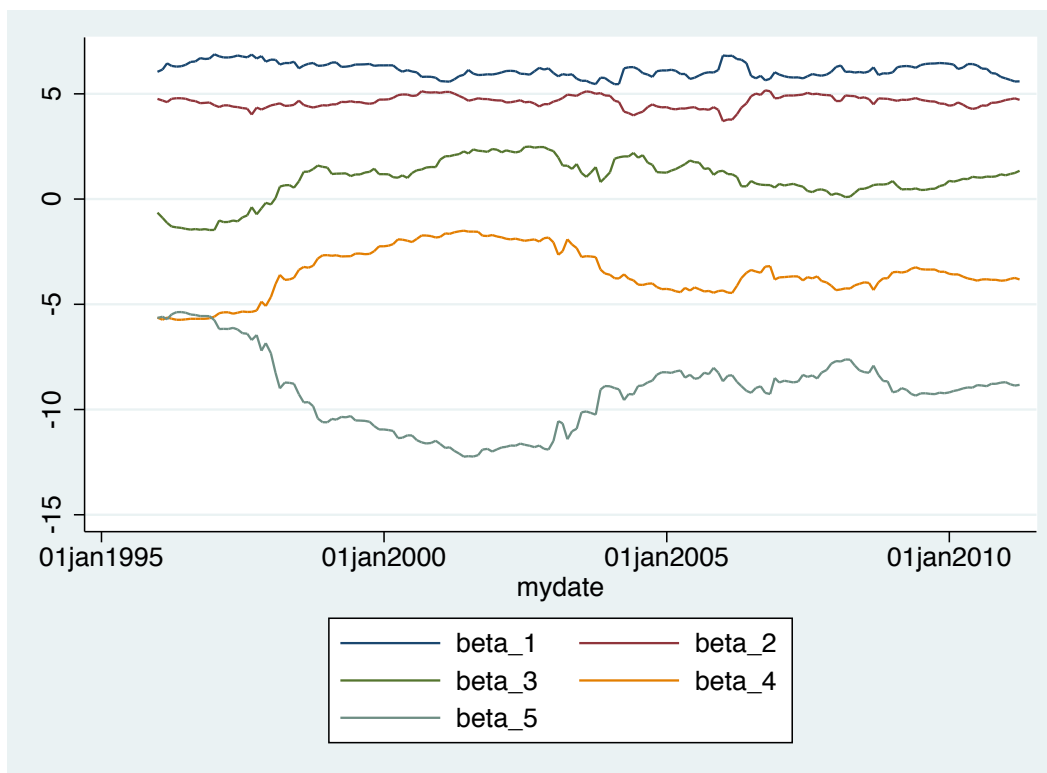

Table 9: **Robustness III: bid-ask spread.** Panel I of this table reports cross-sectional pricing results for the factor model with the dollar risk factor (DOL) and the **skewness factor mimicking portfolio (SKEW_M^{HML})** on five carry trade portfolios, when returns are computed **net of bid-ask spreads**. We estimate factor price of risk by means of two stage GMM. Standard errors (s.e.) of coefficient estimates are obtained according to Newey and West (1987). Panel II reports results for the other moment conditions, counterpart of time-series regressions of excess returns on a constant, the DOL, and the SKEW_M^{HML} factor. HAC standard errors (NeweyWest) are reported in parentheses. Statistical significance has to be interpreted as * $p < 0.05$, ** $p < 0.01$. The sample period is **January 1991 to March 2011**, 243 observations. Returns are monthly.

PANEL I			
	DOL	SKEW _M ^{HML}	
λ	0.252	-0.053**	
s.e.	(0.120)	(0.019)	

PANEL II			
Portfolio	α	DOL	SKEW ^{HML}
1	-0.012 (0.077)	1.206** (0.075)	8.614** (0.813)
2	0.043 (0.033)	1.486** (0.026)	8.641** (0.219)
3	0.136* (0.065)	1.627** (0.055)	4.410** (0.500)
4	-0.106 (0.067)	1.516** (0.073)	-0.504 (0.527)
5	-0.085 (0.098)	1.577** (0.123)	-3.932** (0.769)

Table 10: **Cross-sectional test: Tail Risk Factor (I)**. Panel I of this table reports cross-sectional pricing results for the factor model with the dollar risk factor (DOL) and the **tail factor** on five carry trade portfolios. We estimate factor price of risk by means of two stage GMM. Standard errors (s.e.) of coefficient estimates are obtained according to Newey and West (1987). Panel II reports results for the other moment conditions, counterpart of time-series regressions of excess returns on a constant, the DOL, and the tail factor. HAC standard errors (NeweyWest) are reported in parentheses. Statistical significance has to be interpreted as * $p < 0.10$, ** $p < 0.05$, *** $p < 0.01$. The sample period is **January 1999 to March 2011**, 145 observations. Returns are monthly.

PANEL I			
	DOL	TAIL	
λ	0.371*	-0.017**	
s.e.	(0.193)	(0.006)	

PANEL II			
Portfolio	α	DOL	SKEW ^{HML}
1	-0.427*** (0.110)	0.819*** (0.0612)	10.02 (8.311)
2	-0.104 (0.0663)	0.913*** (0.0335)	11.68*** (3.666)
3	0.108* (0.0553)	1.142*** (0.0305)	9.170** (4.623)
4	-0.0579 (0.0735)	1.116*** (0.0604)	-0.739 (4.617)
5	0.543*** (0.112)	1.018*** (0.0655)	-31.55*** (7.581)

Table 11: **II**. Panel I of this table reports cross-sectional pricing results for the factor model with the dollar risk factor (DOL) and the **tail factor** on five carry trade portfolios. We estimate factor price of risk by means of two stage GMM. Standard errors (s.e.) of coefficient estimates are obtained according to Newey and West (1987). Panel II reports results for the other moment conditions, counterpart of time-series regressions of excess returns on a constant, the DOL, and the tail factor. HAC standard errors (NeweyWest) are reported in parentheses. Statistical significance has to be interpreted as * $p < 0.10$, ** $p < 0.05$, *** $p < 0.01$. The sample period is **January 1999 to July 2007, financial crisis excluded**, 103 observations. Returns are monthly.

PANEL I			
	DOL	TAIL	
λ	0.306	-0.022**	
s.e.	(0.181)	(0.013)	

PANEL II			
Portfolio	α	DOL	SKEW ^{HML}
1	-0.622*** (0.127)	1.022*** (0.133)	3.479 (10.81)
2	-0.112 (0.0792)	0.800*** (0.0683)	13.40*** (4.429)
3	0.129* (0.0586)	1.075*** (0.0592)	6.441 (5.344)
4	0.0484 (0.0673)	0.891*** (0.0638)	7.782* (4.333)
5	0.625*** (0.134)	1.209*** (0.124)	-31.84*** (9.470)

Appendices

A Extreme Value Theory

EVT provides a framework to study the behavior of the tails of the distributions without knowing them completely. We know that, according to the Central Limit Theorem, the limiting distribution of sample averages is a Normal; analogously the limit laws of ordered statistics are described by a class of EVT distributions.

Let x_1, x_2, \dots, x_N be a sequence of stationary i.i.d. random variables and consider the maximum order statistics $M_n = \max(x_1, x_2, \dots, x_n)$ of the first $n < N$ random variables ordered as $x_1 \leq x_2 \leq \dots \leq x_n$. EVT studies the probability of M_n being lower than x , that is $\Pr(M_n \leq x) = \Pr(X_1 \leq x, X_2 \leq x, \dots, X_n \leq x)$ and provide limiting results. Indeed under certain general conditions it can be proved that (Fisher-Tippet theorem, see Gnedenko (1943)) independently from the original distribution of the observed data

$$\Pr(a_n(M_n - b_n) \leq x) \xrightarrow[n \rightarrow \infty]{} G(x), \quad (46)$$

with a_n and b_n normalizing constant and $G(x)$ the Generalized Extreme Value distribution (GVE), given by

$$G(x) = \begin{cases} \exp\left(-\left(1 + \gamma\left(\frac{x-\mu}{\sigma}\right)\right)^{-1/\gamma}\right), & \gamma \neq 0 \\ \exp\left(-\exp\left(-\frac{x-\mu}{\sigma}\right)\right), & \gamma = 0, \end{cases} \quad (47)$$

with μ the location, σ the scale and γ the shape parameter (related to the tail index α). This class of distributions is composed of the so-called max-stable distributions and can be divided into three main subgroups, representing three possibilities for the decay of the density function in the tail:

1. Gumbel type tails: exponential tail decline, all finite moments exist (examples: normal, log-normal, and gamma distributions), $\gamma = 0$

$$\Lambda(x) = \exp(-\exp(-x)), \quad x \in \mathbb{R} \quad (48)$$

2. Frechet type tails: power tail decline (less quick than previous sub-group), fat tail distributions, several finite moments might not exist (examples: Stable, Paretian, Student's t, ARCH type processes), $\alpha = \frac{1}{\gamma}$, $\gamma > 0$

$$\Phi_{\alpha}(x) = \begin{cases} 0 & x \leq 0, \alpha > 0 \\ \exp(-x^{-\alpha}) & x > 0, \alpha > 0, \end{cases} \quad (49)$$

3. Weibull type tails: thin-tailed distributions with a finite upper endpoint, $\alpha = -\frac{1}{\gamma}$, $\gamma < 0$

$$\Psi_{\alpha}(x) = \begin{cases} \exp(-(-x^{-\alpha})) & x < 0, \alpha > 0 \\ 0 & x \geq 0, \alpha > 0. \end{cases} \quad (50)$$

In other words, $\Phi_{\alpha}(x)$ nests the limit of competing fat-tailed density functions, distinguished by different values for the tail index α , that thus characterizes the limit law.

In addition to the previous results, always within the framework of EVT, Beirlant et al. (1996) study statistical properties for events that exceed a certain threshold u , that is once again events in the tails. Given a continuous distribution function $F_X(x)$ and a threshold u smaller than the right end-point of X , the distribution of X above the threshold can be proved to converge to a generalized Pareto distribution (GDP) (described by one parameter γ), that is

$$F_X^u(x) = \Pr(X \leq z | X > u) \sim 1 - (1 + \gamma x)^{-\frac{1}{\gamma}} = \begin{cases} 1 - \exp(-x) & x \geq 0 \quad \text{Gumbel type} \\ 1 - x^{-\alpha}, & x < 1 \quad \text{Frechet type} \\ 1 - (-x)^{\alpha}, & x < 1 \quad \text{Weibull type.} \end{cases} \quad (51)$$

Overall EVT describes the behavior of large observations, independently from the distribution of the fluctuations of the system and it provides also the functional form for the description of the tails.

Extreme events of returns (and many other processes) have been shown to follow empirically a Pareto or a power law tail (see Gabaix (2003)). Thanks to the previous results of EVT, i.e. that the limit of large events for a whole class of distributions follows a Pareto, we are thus equipped with theory supporting the empirical evidences. More formally a process X is said to have a power law tail above the threshold u if

$$(1 - F_X^u(x)) = \Pr(X \geq x) \sim x^{-\alpha}, \quad \text{for } x > u \quad (52)$$

where $\alpha > 0$ is the tail index, i.e. the only parameter that determine the actual shape of the tail (clearly there is an obvious inverse relation between α and the size of a fat tail: the larger α the less fat the tail is). Notice that α represents also the number of existing moments of the distribution: only moments of order lower than α do indeed converge.

The literature introduced several parametric and nonparametric estimators of the tail index α . Among those proposed for the Frechet type tail, in this paper we consider the one introduced by Hill (1975). This the most efficient estimator, moreover it is asymptotically unbiased:

$$\hat{\alpha} = \left(\frac{1}{k} \sum_{i=1}^k \left[\log \left(\frac{x_{(n+1-i)}}{u} \right) \right] \right)^{-1}, \quad (53)$$

where k is the number of observations above the threshold u , n is the total sample size and $x_{(i)}$ denotes the ordered statistics, i.e. $x_{(1)} \leq x_{(2)} \leq \dots \leq x_{(n)}$. Of course the choice of the threshold u is crucial, as too many observations can bias the estimate, while too few can enlarge its variance. Among the several method introduced for jointly estimating α and u we adopt the one of Clauset et al. (2009). We refer to their article for details.

3 Country-Specific Characteristics, Equity Capital Flows and Carry Trade

Sofia Cazzaniga

University of Lugano and Swiss Finance Institute

abstract

We introduce a measure of country specific co-dependence between carry trade excess returns and the equity market of the target country in bad states of the local economy. By means of this measure, we call “downside co-dependence”, we assess that, besides standard risk factors for the currency market, there are country specific characteristics that affect the performance of currency strategies. Sorting currencies according to the country specific downside co-dependence reveals a monotonic pattern in expected carry trade excess returns, we show to be the result of capital flows of international equity investors that react heterogeneously to adverse local market conditions. We therefore introduce a variable tracking these capital flows and we document its explanatory power for the time series of bilateral carry trade returns. Finally, by means of extreme value techniques, we rule out the hypothesis that extreme tail dependence between equity and carry trade returns drive our results.

*The author acknowledges the financial support of the Swiss National Science Foundation (SNSF), Berne (CH).

Special thanks go to Prof. Francesco Franzoni, Prof. Xavier Gabaix for their helpful advice and precious help.

3.1 Introduction

The assessment of factors driving the profitability of currency strategies considerably accelerated in the last years. Starting from Lustig and Verdelhan (2007), who were the first to study the cross section of currency portfolio sorted by interest rates, the literature has been growing very fast. Indeed in order to explain carry trade returns and exchange rate returns several risk factors have been proposed and investigated, see for instance Lustig, Roussanov and Verdelhan (2011) (PCA analysis and HML_{FX} factor), Menkhoff, Sarno, Schmeling and Schrimpf (2012) (global volatility factor), Rafferty (2011) (skewness factor), Mueller, Stathopoulos and Vedolin (2012) (correlation risk factor), Verdelhan (2012) (dollar factor). With the notable exception of the global imbalance risk factor of Della Corte, Riddiough and Sarno (2013)¹⁴, most of the previous factors are derived from currency portfolios sorted according to certain characteristics; they are priced only in the currency market and are not suited for an exhaustive interpretation in terms of fundamentals. As a consequence some researchers have disagreed with the risk-based explanation of carry trade returns. For instance Burnside (2011) strongly criticizes Lustig and Verdelhan (2007) paper and Burnside (2012) states that the traditional risk factors do not work, as carry trade betas are too small for rationalizing the high returns. Yet very recently Dobrynskaya (2012) and Lettau, Maggiori and Weber (2013) overcome this issue thanks to the introduction of a downside market risk factor. Lettau, Maggiori and Weber (2013), in a general framework they call “downside risk CAPM” model, give a unified risk based explanation for currency, equity, commodity and sovereign bonds.

The main goal of all the papers previously mentioned is the successful search for factors that track global shocks cross-sectionally priced; the role of local characteristics is not investigated. Each country though has a peculiar economic system and can be positively or negatively affected by beliefs or by the sentiment of a certain group of investors. Therefore

¹⁴Della Corte, Riddiough and Sarno (2013) risk factor, not only has explanatory power superior to the other factors available in the literature in explaining the variation of currency excess returns, but it also has a clear economic interpretation, as it captures the exposure to countries’ external imbalances.

in this paper we try to fill this gap of the literature, that is we scrutinize whether carry trade investors should better consider certain characteristics, specific of certain countries or of certain groups of countries, besides global factors.

Empirical microstructure literature in the forex market investigated the role of foreign exchange order flow (the difference between buy and sell orders) on exchange rate returns. Evans and Lyons (2002) and Lyons (2001) provide evidence that exchange rate movements are connected to investors behavior that reveals in order flow. They indeed document a high correlation between exchange rates and electronic trading order flow. In addition to this they show that besides being impacted by public information (macro news) even in case of no transactions, exchange rates are influenced by investors order flow and the resulting effect is persistent. Della Corte, Rime and Tsiakas (2013) go beyond these results and show that the predictive ability of customer order flow (mainly asset managers and hedge funds) on exchange rate returns can be exploited for constructing profitable currency trading strategies. Moreover they show that order flow aggregates efficiently the macroeconomic information that is relevant for the understanding of exchange rates.

Among all different players that are sources of currency order flow, here we are specifically interested in international equity investors. As in general they are highly exposed to exchange rate risk, they care about both the volatility of the exchange rate and the correlation structure of exchange rates and foreign equity returns. Therefore in response to good or bad changes in their investment opportunity set they increase or decrease their foreign investments. They thus generate capital flows that theoretically can impact carry trade returns. In other words equity portfolio flows can, at least partly, determine the supply and demand of foreign exchange balances in the short run. We expect this effect to get stronger and stronger through time because of the huge increase of international capital mobility during the last decades.

In the following we measure the effect of capital flows, disentangled from the impact of known sources of risk, induced by international equity investors on the cross section of currency excess returns. We will not rely on proprietary data of currency flows information. Therefore our proxy for capital flows will be given by returns themselves, given that

these two quantities are tightly related. In pursuing our investigation we can rely on the support of previous literature dealing with price transmission channels between equity and currency markets, see for instance Hau and Rey (2006) and Francis, Hasan and Hunter (2006). Francis, Hasan and Hunter (2006) are the first to study dynamic relationships between international equity and currency markets, while previous research simply focused on bivariate interequity/intercurrency relationships. In particular, by means of a trivariate asymmetric GARCH model, they document that there exist significant relationships between equity and currency markets both in the expected returns and in the volatilities. They attribute these connections to spillovers of information conveyed by the mechanism of currency order flow (defined as the net purchase of foreign currency). In particular they show that there are asymmetric volatility spillovers from the equity market to the currency market when bad news to the equity market occur: if investors' appetite for risk changes with bad news in one equity market, portfolio rebalance intensity increases across markets, currency order flow increases and in turn exchange rate moves.

This paper is also related to the literature dealing with downside aversion. It is indeed known that investors are much more averse to losses than attracted by gains (Roy (1952)). This empirical evidence have been theoretically explained in several different ways: rational disappointment aversion in the utility function -Gul (1991), Routledge and Zin (2010)-, utility function with behavioral loss aversion -Barberis, Huang and Santos (2001)-, funding liquidity constraints and liquidity spirals -Brunnermeier and Pedersen (2009)-, fund flows, short-sale constraints -Chen, Hong and Stein (2001). And of course asset pricing models incorporating these evidences have been introduced and tested (see, for instance, Ang, Chen and Xing (2006), Lettau, Maggiori and Weber (2013), Dobrynskaya (2012)).

In agreement with investors putting more weight on bad outcomes (low returns states), we document that capital flows of international equity investors impact exchange rates in states of the world that are bad for the local equity markets.

On a daily rolling basis we compute for each country a measure of downside correlation

between the local equity market in local currency and the carry trade returns of an investor shorting USD and going long the currency of exactly that country. We then sort currencies according to the “previous day country-specific downside beta” and we form portfolios. We document that statistically significant excess returns are left on top of standard risk factors for the currency market, i.e. carry trade and dollar risk. Moreover these alphas turn out to have a monotone decreasing pattern: negative downside beta currencies returns a positive alpha, while positive and high downside beta currencies returns a negative alpha. A positive downside beta means that in bad states for the foreign equity markets, the foreign currency depreciates. We show that these countries are those whose economy strongly relies on the export of primary commodities. As Chaban (2009) points out, a reduction in commodity prices penalizes the equity market of commodity exporting countries and trigger outflows of capital of international equity investors, resulting in foreign currency depreciation. This mechanism leaves carry trade investors with a negative expected excess return. The explanation is different, but still based on capital flows, for currencies having a negative downside beta. In this case if the local market perform badly, its currency strengthens and mitigates the losses of international equity investors long in that equity market. Currency appreciation in turn yields carry trade investors with a positive alpha. The negative beta is a consequence of the portfolio rebalancing activity of international equity investors documented by Hau and Rey (2006). These investors are in general highly exposed to exchange rate risk and, if the performance of the foreign equity market increases substantially, they partly repatriate their investment in order to lower their exposure. The selling order depreciates the foreign currency and generates a negative correlation between local equity and exchange rate returns (country specific counter-cyclical of the exchange rate).

To sum up: we show that sorting individual currencies carry trade returns according to their past downside beta with their respective local equity markets, reveals important information on the capital flows of international equity investors. We collect this information in a variable we call “Flow Currency Variable” and we document that it has a discrete power in explaining the time series of excess returns of individual currencies.

Finally our paper relates to the literature dealing with the role of extreme observations in return series and with extreme value theory applications to finance. The recent financial crisis highlighted the importance of asymmetry in return distribution and of rare events in asset pricing and portfolio choice. Models relying on standard correlation for measuring co-movement among assets can indeed understate the true risk. Indeed correlation measures the average deviations from the mean and gives the same weight to extreme realizations as to the other observations in the sample. Correlation is therefore not a good measure of dependency if extreme realizations are important. Extreme value theory, instead, provides several parametric and non-parametric tools for modeling joint-tail return distributions between return series and it is shaped exactly to deal with extreme events. In particular we use the $\bar{\chi}$ measure adopted by Poon, Rockinger and Tawn (2004) for measuring the tail dependence between returns on the foreign equity market and on the foreign exchange trading strategy.

This analysis is aimed at verifying whether our results previously obtained with downside beta sorted portfolios are driven by dependence between extreme observations in lower tails of the series. In other words we want to test if they are driven by crashes of the equity markets, or if they are indeed truly reflecting the aversion of foreign international investors to bad states of the local markets (that is downside aversion). Downside aversion differs from aversion to crashes. “*Downside betas*” tracks the covariance of asset’s return with the market in bad states, i.e. states of poor performance; “*crash betas*” pertains to extremal negative observations, i.e. those deep-into-the-tails, that happen with very low probability. We do not claim $\bar{\chi}$ to be an exhaustive measure of dependence during crashes, but as it is designed to measure the “correlation between two series in the tails”, it can in principle track different information from those summarized by the downside beta. Therefore in analogy to the previous analysis we employ $\bar{\chi}$ for sorting currencies into portfolios, but this time no significant alpha is left on the table. We therefore rule out the crash story.

The paper is organized as follows: in section 3.2 we describe the data we use and in section 3.3 we illustrate the methodology we adopt. In section 3.4 we sort portfolios according

to the country specific measure of downside co-movement, we analyze the implications of the empirical results and we introduce a flow tracking variable. We turn our attention to measures of tail dependence and report the results we get in section 3.8. Robustness tests can be found in section 3.10 and finally in section 3.11 we conclude.

3.2 Data

We obtain data for several countries from Datastream. Following Lustig, Roussanov and Verdelhan (2011), we delete observations of daily spot and forward exchange rates that reveals violations of the covered interest rate parity.

As far as the country equity indexes we rely on the Datastream Global Equity Indexes, that are constructed with a representative sample of stocks covering at least 75 - 80% of total market capitalization of each country. The indexes are in local currency and include dividends distributions (total return index). For the U.S., we use the value-weighted return series from the Center for Research on Security Prices.

After matching the sample of currencies with that of equities we are left with 42 countries, covering the sample period from January 1985 to December 2011: Australia, Austria, Belgium, Brazil, Bulgaria, Canada, Chile, Cyprus, Czech republic, Denmark, Finland, France, Germany, Greece, Hong Kong, Hungary, India, Indonesia, Ireland, Israel, Italy, Japan, Malaysia, Mexico, Netherlands, New Zealand, Norway, Philippines, Poland, Portugal, Russia, Singapore, Slovakia, Slovenia, South Africa, Spain, Sweden, Switzerland, Taiwan, Thailand, Turkey and United Kingdom.

Spot (S_t) and Forward (F_t) exchange rates are measured in number of foreign currency per USD, that is an increase in S_t denotes an appreciation of the US \$. As it is standard in the literature, we deal with log-variables: $s_{j,t} = \log(S_{j,t})$ and $f_{j,t}^k = \log(F_{j,t}^k)$, with k denoting the maturity of the forward contract, and j the currency.

We compute daily carry trade excess returns on currency j (the excess returns obtained shorting USD and investing in the foreign currency) as:

$$r_{j,(t+1)}^{CT} = (i_{j,t}^* - i_t) - (s_{j,(t+1)} - s_{j,t}), \quad (54)$$

where $i_{j,t}^*$ is the one-day foreign interest rate in country j and i_t the one-day US interest rate. As it will be clear in the next paragraphs, we want to study the effect of equity capital flows on exchange rates and excess carry trade returns. These capital flows are known to occur in the very short-run, therefore we will focus on daily horizon.

3.3 Methodology

In this section we illustrate our methodological approach.

We consider a carry trade speculator, concerned not only with global systematic risk, but also with the characteristics of individual countries and/or the characteristics of groups of countries that share economic and financial commonalities. We take the point of view of a US-based speculator who goes short low interest rate and long high interest rate currencies. We conjecture he wants to use some additional criterion beyond the forward discount, to better pick investment and funding currencies, thus improving his investment choices. For instance some exchange rates might be affected by local properties, predictable to a certain extent, or might be affected by the trading activity of other investors even if active in other asset classes. It is indeed the case that interactions between foreign equity, bond, commodity and currency markets are in general complex and the dynamics we observe are the results of several different effects that can amplify or offset each other. We therefore believe that in order to explain the dynamics of carry trade excess returns, the DOL and the HML_{FX} factors, tracking different types of risk globally priced (Vedelhan (2012)), cannot be the end of the story. It is reasonable to conjecture that equity capital flows of un-hedged foreign equity investments can affect carry trade profitability because of spillovers of country specific equity shocks of certain countries, that play specific roles on the global scale.

In order to address these issues we assume that daily excess returns of local equity markets in local currencies are good proxy for country specific information. Dobrynskaya (2012) and Lettau, Maggiori and Weber (2013) show that the carry trade is more correlated with the global market during market downturns than upturns. In other terms they show that downside market risk is priced in the cross section of carry trade returns, while market risk is not. In analogy to these analysis, we test whether bad states of the local economy are

informative; therefore we focus on country specific measures of downside co-movement. Notice that, though, differently from Lettau, Maggiori and Weber (2013), we do not search for global risk factors cross-sectionally priced; our analysis is aimed at studying the explanatory power of downside characteristics, i.e. of country specific characteristics in bad states of the local economy.

We perform the analysis in the following way: for every day t and for each currency j in our sample we compute the downside beta and the upside beta of daily carry trade excess returns on daily foreign equity (in foreign currency units) excess returns over the previous year (thus approximately over the previous 250 days). That is, for each currency j we perform the regression

$$r_{j,t}^{CT} = \alpha_j + \beta_j r_{j,t}^{EQ} + \delta_j D_{j,t} r_{j,t}^{EQ} + \varepsilon_{j,t}, \quad (55)$$

where $r_{j,t}^{CT}$ is the excess carry trade return on currency j , (i.e. that is short the USD and long the foreign currency j), $r_{j,t}^{EQ}$ is the excess return on the equity of country j in local currency units and $D_{j,t}$ is a dummy variable defined as

$$D_{j,t} = \begin{cases} 0, & \text{if } r_{j,t}^{EQ} < 0 \\ 1, & \text{if } r_{j,t}^{EQ} > 0 \end{cases}. \quad (56)$$

In this setting β_j is the downside beta, while $\beta_j + \delta_j$ is the upside beta.

They represent, respectively, the sensitivity of a carry trade strategy shorting USD and long in currency j , to the excess returns of the stock market of the corresponding country j in bad (negative return) and good states (positive returns). For completeness purposes we compute the rolling OLS beta coefficients, that is without differentiating between good and bad states.

3.4 Downside-beta Portfolios

Given the time series of beta for each country, we sort currencies according to their downside beta of the previous day and we form five equally weighted portfolios.

In figure 1 we plot the rolling estimates of downside, upside and OLS beta for some major

currencies in our sample. In the column on the left, labeled (*a*) we find some of the countries which end up in portfolio 1 most of the times, while in the right column labeled (*b*) we find some of the countries ending up in portfolio 5. Clearly upside and downside betas, as expected, move in opposite directions, with standard beta lying most of the times in the middle. We notice that the absolute value of the downside betas is in general larger than the absolute value of the OLS beta. This means that in local market downturns the sensitivity of currency investments to the local equity market increases.

We now analyze the currency portfolios P_i , $i = 1 \dots 5$. Summary statistics is reported in table 12. They do not look like forward discount sorted portfolios, as in that case we would expect monotonically increasing alphas and almost monotonically decreasing skewness (Lustig, Roussanov and Verdelhan (2011)). In addition to this we notice that only the skewness of P5 is negative and significant, being constituted by currencies of countries whose interest rate is high. Interestingly, kurtosis has an increasing pattern. Therefore sorting currencies according to their past country specific downside beta, seems to be connected to the fourth moment of the distribution of excess returns. This is a totally different property from those of forward discount sorted currencies as no kurtosis is recognizable across portfolios (Lustig, Roussanov and Verdelhan (2011)).

3.5 Downside Country Specific Expected Returns

In this paragraph we want to check if country specific downside equity betas enlighten relevant information for the cross section of currency excess returns. To this aim we regress portfolio excess returns on the two standard risk factors for the currency market, the DOL and the HML_{FX} factors (Lustig, Roussanov and Verdelhan (2011)) and we analyze the significance of the loadings and of the alphas of the regressions. Results are reported in table 13. Table 14 reports the same regressions including lagged returns and factors.

All the portfolios load similarly on the DOL factor, having a coefficient close to unity, that is the high downside beta portfolio minus the low downside beta portfolio, i.e. $P5 - P1$ is uncorrelated with dollar risk. Low downside-beta portfolios ($P1$ and $P2$), those having negative downside-betas, load negatively on the carry trade factor HML_{FX} . They are indeed

constituted by low interest rate countries whose exchange rate appreciates if their economy performs badly. In other terms, portfolio 1 is constituted by currencies that are counter-cyclical with the local economy of the country they belong to. Instead high downside-beta portfolios (*P5* and *P4*), have positive downside-beta and load positively on the carry factor. Thus differently from the previous case, portfolio 5 is constituted by pro-cyclical currencies, i.e. currencies that depreciate in bad states of the local economy and that at the same time belongs to countries having high interest rates. We conclude that, even if sorting currencies on the basis of past day downside-beta does not correspond to sorting currencies on the basis of past interest rate differential, monotone exposure to the carry factor is similarly revealed.

As far as the alphas, they are statistically significant and almost monotonically decreasing. This suggests that sorting currencies on the basis of their sensitivity to bad states of the local equity market reveals valuable information. Let us start with portfolio 1. The alpha on this portfolio is positive and statistically significant and equal to 1.77% on an annual basis. Yet countries in this portfolio have low interest rates and therefore their raw returns are not that high and desirable. The inspection of the composition of portfolio 1 reveals that most of the times it is constituted by the Swiss Franc, the Netherlands Guilder, the British Pound and the Denmark Krone. Currencies in portfolio 2 are the Japanese Yen, the French Franc, the Hong Kong Dollar, and the expected alpha on this portfolio is smaller in absolute value than that on portfolio 1. We point out that, as carry trade investors go short low interest rate currencies, they rather choose currencies belonging to portfolio 2, as those of portfolio 1 can cause a sure expected loss.

We now consider portfolios 4 and 5 which most of the times contains the Australian Dollar, the South African Rand, the Canadian Dollar, the New Zealand Dollar, the Turkish Lira, the Mexican Peso, . . . , that is mainly commodity currencies¹⁵. We notice that these

¹⁵From now on by commodity currencies we will denote those belonging to countries that are exporters of primary commodities (coal, crude oil, gold, wool, natural gas, pulp, lumber, meat, diary products).

portfolios load positively on the carry factor, i.e. they are high interest rate currencies. Portfolios 4 and 5 have very different expected excess returns: portfolio 5 returns an annual statistically significant negative alpha of -2.69% , while the alpha of portfolio 4 is lower in absolute value and in addition insignificant. Thus a carry trade investor would rather pick target currencies among those belonging to portfolio 4. A strategy going long portfolio 5 and short portfolio 1 returns an annually negative expected return of -4.47% , after controlling for the dollar and the carry factor.

Why sorting currencies according to their own country specific downside characteristic reveals a monotone decreasing pattern in expected excess returns? The explanation can be found in international capital flows of money.

A carry trade strategy shorting USD and investing in currencies belonging to portfolio 1 (for instance the Swiss Franc) is negatively correlated with the excess returns of the local equity market, measured in local currency. This means that whenever the Swiss equity market perform well, carry trade on that market performs badly, that is the Swiss Franc depreciates; namely the strength of the country is not associated with that of the currency. This empirical evidence has been extensively investigated by Hau and Rey (2006) for a selected group of countries (that indeed coincides with those ending up in portfolios 1 and 2). Moreover in an incomplete foreign exchange trading setting, they develop a theoretical model explaining these results in terms of portfolio rebalancing dynamics. More in details, US-based equity investors investing internationally hold foreign market risk and exchange risk at the same time¹⁶. Therefore a positive shock to the foreign equity market overexposes their portfolio to exchange rate risk and thus triggers withdrawals. These capital outflows from the foreign country determines excess supply of foreign currency, in other words foreign currency depreciation and bad carry trade performance.

The correlation between local equity excess returns and excess carry trade returns gets more negative (bigger in absolute value) in bad states of the foreign equity market: nega-

¹⁶It is known that they do not usually hedge their foreign positions, see Levich, Hayt and Ripston (1999)

tive shocks to the foreign equity will be alleviated by appreciation of the foreign currency and no outflows of money will be triggered. Therefore, after controlling for standard risk factors for the currency markets, that take into consideration other types of dynamics driving carry trade performance, thanks to the negative correlation we are left with a positive expected excess return.

We now turn our attention to currencies in portfolio 5, that is those having high and positive downside betas. A positive beta stands for foreign currency appreciation in good states for the foreign equity markets. Hau and Rey (2006) portfolio rebalancing arguments do not apply in this case. This is consistent with Chaban (2009), who documents that the “portfolio-rebalancing story is not supported for commodity-producing countries”; in other words in this case the strength of the local equity market is associated with the strength of the currency. The motivation given by Chaban (2009) is based on role that commodity prices play in these economies, and he finds theoretical support in Pavlova and Rigobon (2007). A positive shock in commodity prices boosts equity returns up and induce appreciation of commodity currencies. This is a consequence of the transfer of wealth from commodity importing to commodity exporting countries (Engel (2005)). On the other hand negative shocks to commodity prices negatively affect commodity exporting equity market. Thus international investors drastically lower their return expectations on these foreign markets. As a consequence a negative shock to local equity triggers portfolio outflows of money, excess supply of foreign currency, i.e. foreign currency depreciation. This is the reason why, after controlling for other mechanisms taking place in the FX market (DOL and HML_{FX}), the expected excess return on portfolio 5 is -2.69% on an annual basis. Alpha, instead, is not statistically significant for high interest rate countries whose economy is not strongly dependent on exports of raw commodities (i.e. portfolio 4).

3.6 Country-Specific Downside versus Global Downside

It is natural to investigate the pattern of the expected excess returns when portfolio sorting is done according to other measures of correlation with stock markets. To address this

issue in table 15 we report the expected excess returns (that is controlled for DOL and HML) of currency portfolios sorted according to upside and OLS beta measure with local equity markets, respectively in the first and second row. Some of the OLS betas sorted portfolios have statistically significant alphas, yet the pattern is not clearly monotone and the statistical significance holds only for two out of five portfolios, differently from the case of downside beta sorted portfolios in table 13. Though upside and OLS betas share a high degree of co-movement with downside betas, their cross-sectional spread is not informative enough.

The last three rows of table 15 refer to the sorting done exploiting OLS betas computed on the aggregate equity market, once again on a rolling basis. Global downside beta is computed in analogy with eq.(55) and (56), but this time it measures the sensitivity to the aggregate equity market (as in Lettau, Maggiori and Weber (2013), we use the value-weighted CRSP US equity market log excess return). In these two cases no interesting statistically significant patterns are identifiable. This is once again a result not surprising. Lettau, Maggiori and Weber (2013) shows that CAPM model does not explain the cross section of currencies excess returns, as the factor loadings turn out to be too low, while the downside risk CAPM does. Furthermore they state that the downside risk CAPM on currencies “capture the information contained in the principal component that is relevant for the cross-section”, [...] that is “it summarizes the two principal components” (Lettau, Maggiori and Weber (2013)), which are indeed the DOL and the HML factor as shown by Lustig, Roussanov and Verdelhan (2011). Therefore an analysis aimed at tracking downside global market risk cannot succeed in capturing significant information besides that contained in the two principal components.

We conclude that, even if equity shocks are in general correlated internationally, country specific downside betas highlight different properties from those tracked by global downside risk.

3.7 Flow Tracking Variable

In the previous paragraph we showed that sorting currencies according to country specific downside beta reveals the impact of capital flows of international equity investors on foreign exchange excess returns.

In this paragraph we construct a variable that summarizes the information of capital flows and we check whether it accounts for a share of individual foreign excess returns time-series. We take the high minus low portfolio (that is $P5 - P1$ in table 13). By construction we know that it is uncorrelated with the dollar factor, but it turns out to be highly correlated with the carry factor (the correlation is 51.24%). We therefore take the orthogonal component of $(P5 - P1)$ with respect to HML_{FX} and we denote it as “Flow variable”¹⁷. The annualized mean of the flow factor is -4.61% .

The flow variable represents the loss that a carry trade investor faces when he invests in high interest rate countries, whose economy strongly depends on exports of raw materials, and shorts low interest rate countries for which the portfolio rebalancing argument of Hau and Rey (2006) holds and has visible effects on the exchange rate.

Negative values of the factor stand for money outflows from foreign countries with high interest rates (therefore depreciation of the foreign exchange rate) and for money inflows in countries with low interest rates (therefore appreciation of the foreign exchange rate). These are both obviously unattractive events for a carry trade investor.

We now test the explanatory power of the flow variable for the time series of daily FX excess returns. We run country-level regression of daily CT excess returns of each currency in our sample on the DOL, the HML_{FX} and on the Flow_variable.

Results are reported in table 16 for developed countries, in table 17 for countries whose currency converged to the euro and in table 18 and 19 for emerging/developing countries. Notice that for each currency on the left-hand-side of each regression, we excluded that currency from every portfolio which is used as a regressor on the right-hand-side. As expected high interest rate currencies like Australia, Canada and new Zealand load positively on the

¹⁷In order to assess the contribution of the flow variable, we regress it on HML_{FX} and we keep the residuals of the regression, which by construction are uncorrelated with the regressors.

Flow_factor, while low interest rate currencies load negatively. In addition to this we notice that the Flow_variable improve the fitting of excess carry trade returns, as the R^2 of the regression increases with respect to the specification with only the DOL and the HML_{FX} factor. Of course, as Vedelhan (2012) underlines, high R^2 do not imply that we can easily forecast bilateral exchange rates, as regressions are done with contemporaneous variables at time t (except for the forward discount known at time $(t - 1)$). But, as the R^2 are very far from zero, we can at least explain a substantial fraction of the pattern of daily excess returns and with the flow dynamics increase this fraction a little more.

3.8 Tail Dependence

Measures of dependence between financial time series based on standard correlation take into account small movements around the mean and discard large swings. As a consequence they cannot describe the dependence between extreme events. In recent years the investigation of the tails of the return distribution, have become a major issue in financial risk management, as asset returns are characterized by heavy tails (Gabaix, Parameswaran, Plerou and Stanley (2003)). In other words, extraordinary downside losses are more likely to happen than those expected under Gaussian framework. Tail properties are important not only when dealing with financial series in isolation (univariate framework), but also when studying co-movement between financial variables (multivariate framework). This is the reason why, after being initially introduced by Sibuya (1960), the concept of tail dependence, and of correlation in the tails, has been widely investigated and different measures, both parametric and non-parametric have been introduced.

The coefficient of tail dependence between two assets is defined as the probability that one of the two assets undergoes a large loss (or gain) assuming that the other asset also undergoes a large loss (or gain). The downside country specific betas $\beta_{j,t}^D$ we used in the previous sections measure the sensitivity of daily foreign exchange excess returns to bad states of the country equity market, so it is not designed to specifically model deep-into-the tails observations. It might be the case that our previous results are driven by very

extreme observations happening with very low probability, i.e. observations identifiable as crashes. In this case our flow story explanation could be still valid, but capital flows would be triggered by extreme markets/commodities movements. That is shocks that occur during normal market conditions and that negatively affect stock/commodity markets would not be a major concern for international equity investors. They therefore would not move instantly their capital and no impact of flows on exchange rates would be detectable.

In the following we present the basics of two measures developed in the context of multivariate extreme value theory (see Poon, Rockinger and Tawn (2004)) and designed to quantify extremal association of two variables in the tails. We use them to study tail dependence between CT and local equity excess returns.

Given two marginal series (X, Y) ¹⁸ we want to quantify their multivariate dependence in the tails. For the upper tail we can simply look at the following conditional probability

$$\Pr(q) = \Pr(Y > F_Y^{-1}(q) | X > F_X^{-1}(q)) \quad (57)$$

where F_x and F_y are the respective marginal distribution functions for X and Y . $\Pr(q)$ represents the probability that the variable X is above the q -th percentile of its distribution, conditional on the variable Y being above its q -th percentile¹⁹.

The computation of $\Pr(q)$ can be performed easier if we remove the influence of the marginal aspects by transforming the raw data to two new variables (S, T) , by means of the Frechet transformation, that is:

$$S = -1/\log F_x(X) \quad T = -1/\log F_y(Y). \quad (58)$$

It can be proved that S and T have now the same marginal distribution

$$F(s) = \Pr(S \leq s) = \Pr(T \leq s) = e^{-1/s}, \quad s > 0, \quad (59)$$

¹⁸In our case X will be the excess return on the foreign equity market in its currency units and Y will be the FX excess return of a strategy going long the foreign currency and short the US \$.

¹⁹Similarly we can study the conditional probability for the lower tail. This is indeed the case we are interested in as we are concerned with bad states of the equity market negatively impacting carry trade performance. Yet we present the theory for the upper tail, standard practice in the literature.

but they keep the same dependence structure of the one between X and Y . Besides studying $\Pr(q)$ for finite values of q , we can study its asymptotic behavior, i.e. deep into the tails. More precisely, S and T are said to be asymptotically independent if $\Pr(q)$ has a limit equal to zero as $q \rightarrow 1$; if not they are said to be asymptotically dependent. Asymptotic dependence means that, as one of the two variable moves deeper into the tail, extreme events for the other are expected with positive probability, i.e. the dependence between the two variables persists in the limit.

Given this preliminary setting, we can now introduce $\bar{\chi}$ and χ , defined in Ledford and Tawn (1996), Coles, Heffernan and Tawn (1999), Poon, Rockinger and Tawn (2004), that measure tail dependence respectively in the asymptotic and in the finite case:

$$\chi = \lim_{q \rightarrow 1} \Pr(q) = \lim_{s \rightarrow \infty} \Pr(T > s | S > s), \quad \chi \in [0, 1] \quad (60)$$

$$\bar{\chi} = \lim_{s \rightarrow \infty} \frac{2 \log \Pr(S > s)}{\Pr(T > s, S > s)} - 1, \quad \bar{\chi} \in (-1, 1]. \quad (61)$$

Notice that S and T are asymptotically dependent if $\chi > 0$.

$\bar{\chi}$ can be interpreted as a sort of ‘‘correlation applied to points in the tail area’’.

It can be proved that if $\bar{\chi} = 1$ the two variables are asymptotically dependent. Hence we proceed as follow: we firstly compute $\bar{\chi}$ and we test if it is different from 1. If we cannot reject $\bar{\chi} = 1$, we deduce that S and T are asymptotically dependent and we estimate χ . If instead $\bar{\chi}$ is significantly different form 1, we deduce the two variables are asymptotically independent and we use $\bar{\chi}$ as measure of tail dependence at finite values.

Poon, Rockinger and Tawn (2004) give also the recipe for computing $\bar{\chi}$ and χ by exploiting the Hill estimator. Here we simply state results, we refer to Poon, Rockinger and Tawn (2004) and Ledford and Tawn (1996) for details and proofs (a brief description of the Hill estimator and of the used estimation methodology used is given in appendix B).

Under weak conditions the joint cumulative distribution of S and T in the tails behaves as

$$\Pr(S > s, T > s) \sim \mathcal{L}(s)s^{-1/\eta}, \text{ for } s \rightarrow \infty, \quad (62)$$

where $\mathcal{L}(s)$ is a slowly varying function and $\eta \in (0, 1]$. η can be shown to be the tail index of a new variable $Z = \min(S, T)$:

$$\Pr(S > s, T > s) = \Pr(\min(S, T) > z) = \Pr(Z > z) = \mathcal{L}(z)z^{-1/\eta}, \quad z > u, \quad (63)$$

with u a sufficiently high threshold. Thus its estimated value $\hat{\eta}$ can be obtained via the Hill estimator. Finally, $\bar{\chi}$, χ and their standard errors can be computed as

$$\hat{\chi} = 2\hat{\eta} - 1 \quad \text{Std.Dev.}(\hat{\chi}) = \sqrt{\frac{(\hat{\chi} + 1)^2}{k}}, \quad (64)$$

$$\hat{\chi} = \frac{k}{N}u \quad \text{Std.Dev.}(\hat{\chi}) = \sqrt{\frac{(u^2)k(N-k)}{N^3}}, \quad (65)$$

with k the number of observations z that exceed the threshold \hat{u} , and N the total number of observations of the z variable.

3.9 Estimation of left tail dependence measures $\bar{\chi}$ and χ

Extreme value theory techniques that we are going to use here rely on the assumption of independent data. When non-filtered data are used the behavior of extremes might be driven both by extreme innovation and by the dependence structure (like for instance volatility clustering). In order to avoid any issue of this kind we fit each series in our dataset (both carry trade and equity excess returns) with a univariate AR(2)-GJR-GARCH(1,1) and we keep the residuals. The filtered returns are tested for autocorrelation and heteroscedasticity using respectively Ljung-Box test and Engle test and we verify that the null of no-autocorrelation and of no-arch effect cannot be rejected.

In order to compute tail dependence we need to have a large number of observations, as extreme events are rare. Therefore the choice of daily data is crucial. $\bar{\chi}$ and χ , measuring tail dependence between carry trade excess returns over currency i and excess returns over the equity market of the corresponding country, are computed with a rolling window of 2000 daily observations (8 years). The windows move forward of a day at every step.

We firstly estimate $\bar{\chi}$ for every pair of excess CT returns-excess equity returns and in figure 3 we plot their time series for a bunch of countries: corresponding to those that appear in figure 1. Countries in the left column have on average lower and most of the times negative $\bar{\chi}$ with respect to countries on the right. Yet estimated $\bar{\chi}$ s oscillate and switch signs more often than the down beta, therefore we expect to find different results when sorting currencies into portfolios according to $\bar{\chi}$ from those obtained with down beta.

We then test the null hypothesis $\bar{\chi} = 1$ to assess asymptotic dependence and for all the countries we reject it at 95% confidence level. We deduce that carry trade returns and local excess equity returns are asymptotically independent (in the extremes). This result, however, does not automatically answer our research question: is the pattern in excess CT return portfolios sorted according to downside country specific betas driven by extreme observations, identifiable as crashes? It might be indeed the case that asymptotic dependence is too strict for identifying correlation during crashes, as it is defined in the limit. Different degrees of dependence are attainable at finite levels and we can measure them with $\bar{\chi}$.

We now repeat the same analysis of table 13, adopting $\bar{\chi}$ instead of downside beta, that is each day we sort currencies according to $\bar{\chi}$ of the previous day and we form five 20%–quantile portfolios. We finally regress the excess returns on the standard risk factors DOL and HML_{FX} . Results are reported in table 20 panel (a), while panel (b) contains regression results in case of portfolio sorted according to previous day down beta over the same sample of the series of panel (a). As we can see from panel (a), sorting currencies according to the previous day $\bar{\chi}$ does not evidence any statistically significant α , differently from downside beta sorted portfolios of panel (b). We therefore deduce that dependences in the extremes do not play any role, that is international equity investors move their capital from one country to another according to “normal” movements in the local equity markets. We thus rule out the “crashes-explanation” for results of table 13. We conclude that the flow tracking variable is a measure of capital flows movements induced by equity investors in response to positive and negative shocks in local equity markets.

3.10 Robustness

In this section we test the robustness of our results to different issues.

We start with considering monthly rather than daily returns, that is each month we sort monthly currency excess returns according to their past downside country specific beta, computed using the previous 250 days. In other words, if T denotes the T -th months of the sample and if t^* represent the last day in that month, we compute the downside beta used for sorting excess returns realizing at the end of month T on the sample of 250 days

$[t^* - 250, t^* - 1]$. Analysis are reported in table 21 and are coherent with those of the daily analysis.

We then consider different estimates of downside beta, that is using different cut-off levels. We report results in tables 22 and 23 respectively for cut-off given by $\mu_{j,t}$ and $\mu_{j,t} - 0.5\sigma_{j,t}$, that is choosing dummy variables

$$D_{j,t} = \begin{cases} 0, & \text{if } r_{j,t}^{EQ} < \mu_{j,t} \\ 1, & \text{if } r_{j,t}^{EQ} > \mu_{j,t} \end{cases} \quad (66)$$

and

$$D_{j,t} = \begin{cases} 0, & \text{if } r_{j,t}^{EQ} < \mu_{j,t} - 0.5\sigma_{j,t} \\ 1, & \text{if } r_{j,t}^{EQ} > \mu_{j,t} - 0.5\sigma_{j,t} \end{cases} \quad (67)$$

where $\mu_{j,t}$ is the mean return of the equity market of country j and $\sigma_{j,t}$ the standard deviation. They are dependent on t as they are computed on the same rolling sample over which the regression is performed. Results in both cases are in agreement with results of table 13, though the statistical significance gets weaker. This is not surprising, as according to results of section 3.8 extreme events do not play any important role.

3.11 Conclusion

In this paper, we study downside country-specific characteristics of currencies and we assess their impact on currency excess returns. By means of portfolio sorting approach we identify countries whose excess carry trade returns depend differently and with different strength from the performance of their respective local equity market. We find that the expected excess return decrease monotonically with the level of co-dependence. We attribute our findings to capital movements of international equity investors who react to local equity market conditions. Equity investors move their capital because of portfolio rebalancing issues or in order to unwind positions in markets they consider risky. We sum up capital flows of investors in a factor we call Flow Tracking Variable. We show that it has a significant explanatory power for the time series of bilateral carry trade excess returns on top of standard risk factors for the currency market. The results are robust to different frequencies

(though the effect is in any case short-lived) and to different methods of estimation of the downside co-movement. Not only our results are in agreement with previous papers that investigate the links between currency and stock market, but also they enrich this literature that is, to our knowledge, very little.

Extreme value theory techniques are finally employed in order to recognize whether the results we found are due to aversion to downside or crash events. No evidence of local equity crashes playing a role for carry trade excess returns is found in the data.

Overall our results underline the importance of downside measure of co-movement between excess return on carry trade and those on equity. Indeed a carry trade investor should not only take into consideration standard risk factor tracking dollar and carry trade risk, but also capital flows of international equity investors whose reaction is stronger and relevant in bad rather than good times. Tracking the dependence measure of carry trade from equity excess returns can be very useful as it might be exploited for real-time portfolio selection, Sharpe ratio targeting, and many other applications.

References

- Ang A., J. Chen and Y. Xing, 2006, Downside Risk, *Review of Financial Studies*, 19, 4, 1119-1239.
- Barberis N. and M. Huang and T. Santos, 2001, Prospect Theory and Asset Prices, *Quarterly Journal of Economics*, 116, 1-53.
- Beirlant J., P. Vynckier and J.L. Teugels, 1996, Practical Analysis of Extreme Values, *University Press, Leuven*.
- Brunnermeier M. K. and L. H. Pedersen, 2009, Market Liquidity and Funding Liquidity, *Review of Financial Studies*, 22, 6, 2201-2238.
- Burnside, C., 2011, The Cross-Section of Foreign Currency Risk Premia and Consumption Growth Risk: a Comment, *American Economic Review*, 101, 7, 3456-76.
- Burnside, C., 2012, Carry Trade and Risk, *Handbook of Exchange Rates*, Hoboken: John Wiley & Sons.
- Chaban M., 2009, Commodity Currencies and Equity Flows, *Journal of International Money and Finance*, 28, 836-852.
- Chen J., H. Hong and J. Stein, 2001, Forecasting Crashes: Trading Volume, Past Returns and Conditional Skewness in Stock Prices, *Journal of Financial Economics*, 61, 345-381.
- Christiansen C., A. Rinaldo and P. Soderlind, 2011, The Time-Varying Systematic Risk of Carry Trade Strategies, *Journal of Financial and Quantitative Analysis*, 46, 4, 1107-1125.
- Clauset A., C. R. Shalizi and M. E. J. Newman, 2009, Power Law Distribution in Empirical Data, *SIAM Review*, 51, 4, 661-703.
- Coles S. G., J. Heffernan and J. A. Tawn, 1999, Dependence Measures for Extreme Value Analyses, *Extremes*, 3, 5-38.

- Della Corte P., D. Rime and L. Sarno and I. Tsiakas, 2013, Currency Order Flow and Real-Time Macroeconomic Information, *Working Paper*.
- Della Corte P., S. Riddiough and L. Sarno, 2013, Currency Premia and Global Imbalances, *Working Paper*.
- Dobrynskaya V., 2012, Downside Market Risk of Carry Trades, *Working paper*.
- Engel C., 2005, Canada's Exchange Rate: New Evidence, a Simple Model, and Policy Implications, *In: Canada in the global Economy. Proceedings of a Conference held by the Bank of Canada, Ottawa, Canada*.
- Evans M. and R. Lyons, 2002, Order Flow and Exchange Rate Dynamics, *Journal of Political Economy*, 110, 1, 170-180.
- Francis B., I. Hasan and D. M. Hunter, 2006, Dynamic Relations between International Equity and Currency Markets: The Role of Currency Order Flow, *Journal of Business*, 79, 1, 219-258.
- Gabaix X., G. Parameswaran, V. Plerou and E. Stanley, 2003, A Theory of Power Law Distributions in Financial Market Fluctuations, *Nature*, 423, 267-270.
- Gnedenko B. V., 1943, Sur la Distribution Limits du Terme Maximum d'une Série Aléatoire, *Annals of Mathematics*, 4, 423-453.
- Gul F., 1991, A Theory of Disappointment Aversion, *Econometrica*, 3, 667-686.
- Hau H. and H. Rey, 2006, Exchange Rates, Equity Prices and Capital Flows, *Review of Financial Studies*, 19, 1, 273-317.
- Hill, B. M., 1975, A Simple General Approach to Inference about the Tail of a Distribution, *Annals of Statistics*, 3, 1163-73.
- Ledford A. and J. A. Tawn, 1996, Statistics for Near Independence in Multivariate Extreme Values, *Biometrika*, 83, 169-187.

- Lettau M., M. Maggiori and M. Weber, 2013, Conditional Risk Premia in Currency Markets and Other Asset Classes, *Journal of Financial Economics*, forthcoming.
- Levich R. M., G. S. Hayt and B. A. Ripston, 1998, Survey of Derivative and Risk Management Practices by US Institutional Investors, *Unpublished. Survey Conducted by the NYU Salomon Center, CIBC World Markets, and KPMG. New York University, New York, NY.*
- Lustig H. and A. Verdelhan, 2007, The Cross-Section of Foreign Currency Risk Premia and Consumption Growth Risk, *American Economic Review*, 97, 1, 89-117.
- Lustig H., N. Roussanov and A. Verdelhan, 2011, Common Risk Factors in Currency Markets, *Review of Financial Studies*, 24, 11, 3731-3777.
- Lyons R., 2001, The Microstructure Approach to Exchange Rates, *MIT Press, Cambridge, MA.*
- Menkhoff L., L. Sarno, M. Schmeling and A. Schrimpf, 2012, Carry Trades and Global Foreign Exchange Volatility, *Journal of Finance*, 67, 681-718.
- Menkhoff L., L. Sarno, M. Schmeling and A. Schrimpf, 2013, Information Flows in Dark Markets: Dissecting Customer Currency Trades, *Journal of Finance*, forthcoming.
- Mueller P., A. Stathopoulos and A. Vedolin, 2012, International Correlation Risk, *Working Paper, London School of Economics.*
- Newey W. K. and K. D. West, 1987, A Simple, Positive Semi-Definite, Heteroskedasticity and Autocorrelation Consistent Covariance Matrix, *Econometrica*, 55, 703-708.
- Pavlova A. and R. Rigobon, 2007, Asset Prices and Exchange Rates, *Review of Financial Studies*, 20, 1, 1139-1181.
- Poon S, M. Rockinger and J. Tawn, 2004, Extreme Value Dependence in Financial Markets: Diagnostics, Models, and Financial Implications, *Review of Financial Studies*, 17, 2, 581-610.

- Rafferty B., 2011, Currency Returns, Skewness and Crash Risk, *Working Paper, Duke University*.
- Roy, A. D., 1952, Safety First and the Holding of Assets, *Econometrica*, 20, 431-449.
- Ranaldo A. and P. Soderlind, 2007, Safe Haven Currencies, *Review of Finance*, 14, 3, 385-407.
- Routledge B. and S. Zin, 2010, Generalized Disappointment Aversion and Asset Prices, *The Journal of Finance*, 65, 4, 1303-1332.
- Sibuya M., 1960, Bivariate Extreme Statistics, *Ann. Inst. Statist. Math.*, 11, 195-210.
- Verdelhan A., 2012, The Share of Systematic Variation in Bilateral Exchange Rates, *MIT Sloan School of Management, working paper*.

Figure 14: **OLS beta, upside-beta and down-side beta** of daily carry trade excess return on daily equity excess returns, computed using the previous year of daily data (approximately 250 observations)

(a) Low downside beta

(b) High downside beta



Figure 15: **Daily rolling $\bar{\chi}$** of daily carry trade excess return and daily equity excess returns, computed using the previous 8 years of daily data (approximately 2000 observations)

(a) Low downside beta

(b) High downside beta



Table 12: **Summary Statistics:** summary statistics for excess returns of currency portfolio sorted on downside beta with country specific equity. Standard errors in parenthesis are computed via delta method and GMM and are corrected for heteroskedasticity and autocorrelation with Newey and West (1987). Statistical significance has to be interpreted as * $p < 0.10$, ** $p < 0.05$, *** $p < 0.01$. The sample period starts on January 2 1986 and ends on December 30 2011, excess returns are daily, annualized and in percentage points. Total number of observations 6558.

	Mean	Std. dev.	Skew	Kurt
P1	3.158* (1.758)	8.632*** (0.151)	0.025 (0.081)	5.323**** (0.455)
P2	2.850* (1.488)	7.211*** (0.142)	-0.116 (0.088)	5.848**** (0.578)
P3	1.262 (1.247)	6.052*** (0.176)	0.011 (0.179)	9.411**** (1.840)
P4	3.293** (1.486)	7.484*** (0.312)	-0.177 (0.362)	15.285**** (4.541)
P5	5.173*** (2.076)	10.188*** (0.440)	-0.604*** (0.271)	13.037**** (3.611)

Table 13: **Downside beta sorted portfolios (I)**: this table reports time series regression on the dollar risk factor (DOL) and the carry trade risk factor HML_{FX} . Test assets are daily excess returns on five portfolios sorted according to the previous day downside-beta. HAC standard errors (s.e.) are reported in parentheses and are obtained by the Newey and West (1987) procedure. Statistical significance has to be interpreted as * $p < 0.10$, ** $p < 0.05$, *** $p < 0.01$. The sample period starts on January 2 1986 and ends on December 30 2011. Excess returns are daily, annualized and in percentage points. Total number of observations 6558.

	P1	P2	P3	P4	P5	P5-P1
DOL	1.260*** (0.0348)	1.058*** (0.0200)	0.850*** (0.0187)	0.982*** (0.0320)	1.177*** (0.0310)	-0.0832 (0.0612)
HML_{FX}	-0.248*** (0.0185)	-0.156*** (0.0140)	-0.00729 (0.0115)	0.0837*** (0.0181)	0.426*** (0.0344)	0.674*** (0.0496)
α	1.769* (0.948)	1.170* (0.692)	-1.271** (0.601)	-0.552 (0.895)	-2.694** (1.334)	-4.463** (2.053)
N	6558	6558	6558	6558	6558	6558

Table 14: **(II)**: this table reports time series regression on the dollar risk factor (DOL) and the carry trade risk factor HML_{FX} and their lagged variables. Refer to previous table for interpretation.

	P1	P2	P3	P4	P5	P5-P1
DOL	1.262*** (0.0346)	1.057*** (0.0201)	0.850*** (0.0189)	0.983*** (0.0323)	1.179*** (0.0310)	-0.0830 (0.0612)
Lagged DOL	-0.0763** (0.0309)	-0.00999 (0.0255)	-0.0193 (0.0181)	-0.0127 (0.0274)	0.0132 (0.0403)	0.00230 (0.0223)
HML	-0.247*** (0.0184)	-0.157*** (0.0139)	-0.00736 (0.0114)	0.0844*** (0.0180)	0.428*** (0.0343)	0.674*** (0.0493)
Lagged HML	0.0157* (0.00868)	0.00292 (0.00903)	-0.00158 (0.00777)	-0.0130 (0.0117)	-0.0105 (0.0167)	-0.0453* (0.0235)
Lagged Return	0.0357* (0.0205)	0.0185 (0.0156)	0.0204* (0.0117)	0.00472 (0.0173)	-0.0371 (0.0262)	0.0552** (0.0239)
α	1.719* (0.921)	1.122 (0.703)	-1.265** (0.607)	-0.396 (0.889)	-2.533* (1.331)	-4.133** (1.967)
N	6557	6557	6557	6557	6557	6557

Table 15: **Alpha_{DOL,HML_{FX}}**: this table reports the alpha of the time series regression on the dollar risk factor (DOL) and the carry trade risk factor HML_{FX} of portfolios of currencies sorted according to different measures of lagged realized betas. β denotes the OLS beta with the local equity market in local currency. The prefix “global” stands for OLS, downside and upside betas computed using the aggregate equity market. HAC standard errors (s.e.) are reported in parentheses and are obtained by the Newey and West (1987) procedure. Statistical significance has to be interpreted as * $p < 0.10$, ** $p < 0.05$, *** $p < 0.01$. The sample period start on January 2 1986 and ends on December 30 2011, excess returns are daily, annualized and in percentage points. Total number of observations 6558.

	P1	P2	P3	P4	P5
upside_β	2.160** (0.911)	-0.690 (0.806)	-0.201 (0.689)	-1.046 (0.938)	-2.115* (1.140)
β	2.585*** (0.940)	0.676 (0.870)	-0.850 (0.632)	-2.239** (0.944)	-2.015 (1.321)
global_β	-0.107 (1.058)	0.292 (0.763)	0.222 (0.750)	-0.0467 (0.997)	-1.109 (1.381)
global_down_β	-0.806 (1.047)	1.586** (0.790)	-1.335** (0.675)	-1.042 (1.020)	1.136 (1.308)
globalUp_β	0.215 (0.990)	0.900 (0.780)	0.283 (0.763)	-0.215 (0.893)	-2.279* (1.265)

Table 16: **Developed countries:** this table reports time series country-level regression of daily excess rate returns r_t^{CT} on the lagged forward discount ($f_{t-1} - s_{t-1}$), on the DOL factor, the carry factor HML_{FX} and the Flow TV. The table reports also the number of observations N and the R^2 of the regression in percentage points. R_{HML}^2 denotes the R^2 with only the carry factor, and $R_{HML,DOL}^2$ with bot of them. The last R^2 is for the full specification of factors, that is including the Flow factor. Standard errors in parenthesis are computed according to Newey and West (1987). Statistical significance and has to be interpreted as * $p < 0.10$, ** $p < 0.05$, *** $p < 0.01$. Finally we report the F-test, testing the null hypothesis that the coefficients of the regression are jointly zero. ** * denotes rejection of the null hypothesis at the 1% significance. Daily data from January 2 1986 to December 30 2011.

	Australia	Canada	Denmark	Japan	New Zealand	Norway	Sweden	Switzerland	United Kingdom
fwdDt _(t-1)	0.0278 (0.0317)	0.0386 (0.0293)	0.0127 (0.0158)	0.0457 (0.0323)	0.0495* (0.0297)	-0.0464** (0.0231)	-0.0222 (0.0276)	0.0187 (0.0219)	-0.0352 (0.0510)
hml _{FX}	0.144*** (0.0438)	0.0855*** (0.0156)	-0.265*** (0.0127)	-0.238*** (0.0277)	0.0709** (0.0314)	-0.137*** (0.0169)	-0.117*** (0.0192)	-0.378*** (0.0183)	-0.0713*** (0.0155)
dol1	0.965*** (0.0444)	0.470*** (0.0304)	1.586*** (0.0172)	0.715*** (0.0516)	1.022*** (0.0417)	1.590*** (0.0270)	1.536*** (0.0314)	1.608*** (0.0267)	1.138*** (0.0238)
Flow_TV	0.334*** (0.0434)	0.177*** (0.0239)	-0.236*** (0.0102)	-0.258*** (0.0344)	0.315*** (0.0331)	-0.0947*** (0.0173)	-0.0567** (0.0222)	-0.358*** (0.0170)	-0.100*** (0.0168)
α	0.154 (2.723)	-0.119 (1.408)	-0.828 (0.791)	2.492 (2.568)	-0.945 (2.787)	1.424 (1.515)	-1.207 (1.387)	-0.619 (1.582)	0.508 (2.244)
N	6558	6558	6558	6558	6558	6558	6558	6558	6558
R_{HML}^2	0.28	0.37	0.39	0.23	2.05	1.14	0.29	2.55	3.67
$R_{HML,DOL}^2$	25.62	16.79	78.50	17.30	24.37	66.46	62.29	61.53	47.96
R^2	31.95	21.20	82.62	21.65	29.69	67.00	62.48	69.11	48.82
F-test	***	***	***	***	***	***	***	***	***

Table 17: **Developed countries converged to the Euro:** this table reports time series country-level regression of daily excess rate returns rx^{CT} on the the lagged forward discount ($f_{t-1} - s_{t-1}$), on the DOL factor, the carry factor HML_{FX} and the Flow TV. The table reports also the number of observations N and the R^2 of the regression in percentage points. R_{HML}^2 denotes the R^2 with only the carry factor, and $R_{HML,DOL}^2$ with bot of them. The last R^2 is for the full specification of factors, that is including the Flow factor. Standard errors in parenthesis are computed according to Newey and West (1987). Statistical significance and has to be interpreted as * $p < 0.10$, ** $p < 0.05$, *** $p < 0.01$. Finally we report the F-test, testing the null hypothesis that the coefficients of the regression are jointly zero. *** denotes rejection of the null hypothesis at the 1% significance. Daily data from January 2 1986 to December 30 2011.

	Austria	Belgium	Germany	Spain	Finland	France	Ireland	Italy	Netherlands	Portugal	Cyprus	Greece
fwdDiscount _(t-1)	-0.0993*** (0.0182)	-0.0419 (0.0321)	-0.00553 (0.0169)	-0.107*** (0.0300)	-0.137*** (0.0469)	-0.0377 (0.0243)	-0.0343 (0.0606)	-0.0660 (0.0535)	0.0126 (0.0166)	-0.131*** (0.0316)	0.00247 (0.0307)	-0.0292 (0.0812)
hml _{FX}	-0.230*** (0.0218)	-0.217*** (0.0219)	-0.240*** (0.0139)	-0.226*** (0.0223)	-0.217*** (0.0232)	-0.179*** (0.0165)	-0.138*** (0.0232)	-0.118*** (0.0244)	-0.224*** (0.0140)	-0.227*** (0.0231)	-0.236*** (0.0211)	-0.191*** (0.0298)
dol	1.303*** (0.0366)	1.300*** (0.0379)	1.562*** (0.0244)	1.247*** (0.0372)	1.244*** (0.0369)	1.494*** (0.0239)	1.154*** (0.0381)	1.327*** (0.0309)	1.590** (0.0254)	1.253*** (0.0361)	1.408*** (0.0262)	1.409*** (0.0479)
Flow_TV	-0.268*** (0.0207)	-0.261*** (0.0204)	-0.286*** (0.0108)	-0.252*** (0.0205)	-0.249*** (0.0241)	-0.274*** (0.0130)	-0.178*** (0.0297)	-0.222*** (0.0216)	-0.269*** (0.0122)	-0.248*** (0.0205)	-0.231*** (0.0213)	-0.280*** (0.0283)
α	-4.331** (1.857)	-2.071 (2.144)	-0.339 (0.941)	-0.390 (1.942)	-7.886*** (2.649)	1.978* (1.108)	2.814 (2.003)	7.656* (4.236)	-0.0169 (0.940)	-0.798 (1.884)	-0.902 (1.335)	5.547 (7.360)
N	505	505	3287	505	505	3287	1306	3287	3287	505	947	1009
R_{HML}^2	19.10	17.65	0.10	19.73	17.24	0.01	8.84	0.07	0.10	19.27	2.22	9.12
$R_{HML,DOL}^2$	76.86	75.96	81.97	76.11	72.23	78.21	58.11	64.11	83.18	75.00	80.23	50.20
R^2	86.11	84.81	87.26	84.77	80.64	82.98	6.69	67.34	87.75	83.19	82.92	56.46
F-test	***	***	***	***	***	***	***	***	***	***	***	***

Table 18: **Emerging Countries (I)**: this table reports time series country-level regression of daily excess rate returns rx^{CT} on the lagged forward discount $(f_{t-1} - s_{t-1})$, on the DOL factor, the carry factor HML_{FX} and the Flow TV. The table reports also the number of observations N and the R^2 of the regression in percentage points. R^2_{HML} denotes the R^2 with only the carry factor, and $R^2_{HML,DOL}$ with bot of them. The last R^2 is for the full specification of factors, that is including the Flow factor. Standard errors in parenthesis are computed according to Newey and West (1987). Statistical significance and has to be interpreted as $p < 0.10$, $** p < 0.05$, $*** p < 0.01$. Finally we report the F-test, testing the null hypothesis that the coefficients of the regression are jointly zero. $***$ denotes rejection of the null hypothesis at the 1% significance. Daily data from January 2 1986 to December 30 2011.

	Slovenia	Bulgaria	Czech Republic	Hungary	Poland	Russia	Turkey	Chile	Israel	Mexico
fwdDiscount $_{(t-1)}$	-0.0646 (0.0457)	0.0286 (0.0411)	0.0359 (0.0455)	0.0774** (0.0339)	0.0662*** (0.0186)	-0.0267 (0.0290)	0.0178*** (0.00486)	0.00166 (0.104)	0.0195 (0.110)	0.0652** (0.0254)
hml $_{FX}$	-0.246*** (0.0283)	-0.286*** (0.0278)	-0.163*** (0.0334)	-0.101*** (0.0275)	-0.00932 (0.0391)	-0.0651* (0.0344)	0.179*** (0.0442)	0.304*** (0.0434)	0.0722* (0.0410)	0.263*** (0.0608)
dol	1.347*** (0.0283)	1.539*** (0.0288)	1.590*** (0.0402)	1.926*** (0.0423)	1.458*** (0.0536)	0.763*** (0.0416)	0.948*** (0.0462)	0.614*** (0.0429)	0.607*** (0.0355)	0.393*** (0.0673)
Flow_TV	-0.264*** (0.0242)	-0.179*** (0.0270)	-0.116*** (0.0271)	-0.0347 (0.0376)	0.0522 (0.0417)	0.0952*** (0.0326)	0.161*** (0.0460)	0.178*** (0.0475)	0.0233 (0.0319)	0.287*** (0.0694)
α	-1.131 (1.507)	-2.198 (1.337)	-0.112 (2.200)	-10.87** (4.818)	-6.878** (3.428)	3.581 (2.463)	0.461 (4.382)	-0.586 (4.097)	0.134 (3.061)	-8.926** (3.782)
N	695	1955	3783	3568	3866	1955	3486	1955	1955	3776
R^2_{HML}	7.47	0.03	0.00	0.41	0.88	1.71	4.92	10.57	3.52	9.45
$R^2_{HML,DOL}$	80.96	76.52	44.96	61.91	37.15	40.64	27.38	28.32	25.65	17.35
R^2	84.10	78.21	45.58	61.95	37.26	41.31	28.72	29.79	25.68	23.90
F-test	***	***	***	***	***	***	***	***	***	***

Table 19: Emerging Countries (II)

	South Africa	Hong Kong	India	Indonesia	Malaysia	Philippines	Singapore	Taiwan	Thailand	Brazil
$\text{fwdDiscount}_{(t-1)}$	0.0515*** (0.00667)	0.0551*** (0.00509)	0.0875*** (0.0291)	0.101* (0.0526)	0.0264 (0.0260)	-0.0623 (0.0648)	0.000274 (0.0346)	-0.0303 (0.0204)	-0.0244 (0.0503)	0.0446 (0.0475)
hml_{FX}	0.0981*** (0.0313)	-0.000864 (0.00108)	0.0319** (0.0135)	0.131 (0.106)	0.201*** (0.0425)	0.0904*** (0.0255)	-0.00471 (0.0110)	0.0195* (0.0107)	0.0218 (0.0352)	0.656*** (0.0754)
dol	1.199*** (0.0451)	0.0158*** (0.00169)	0.285*** (0.0209)	0.228* (0.138)	0.549*** (0.0625)	0.290*** (0.0301)	0.516*** (0.0173)	0.227*** (0.0151)	0.407*** (0.0414)	0.830*** (0.0561)
Flow_TV	0.273*** (0.0423)	0.00153 (0.000998)	0.0614*** (0.0170)	0.692*** (0.187)	0.390*** (0.0696)	0.167*** (0.0276)	0.141*** (0.0155)	0.0377*** (0.0114)	0.217*** (0.0582)	0.503*** (0.0693)
α	-9.309*** (2.719)	0.0172 (0.0990)	-6.647*** (2.498)	-29.12** (13.24)	-5.922*** (2.276)	7.260 (5.490)	-0.539 (1.335)	-2.697** (1.280)	3.528 (2.983)	0.984 (8.753)
N	6558	6558	3568	2166	3202	3776	6558	3776	4229	1955
R^2_{HML}	3.41	2.58	2.25	1.67	4.16	2.34	0.40	0.81	0.63	18.23
$R^2_{HML,DOL}$	26.52	5.15	14.00	3.17	10.22	7.15	34.26	10.67	6.50	40.92
R^2	29.34	5.20	15.80	5.75	22.15	9.79	39.79	11.22	9.34	47.02
F-test	***	***	***	***	***	***	***	***	***	***

Table 20: $\bar{\chi}$ sorted portfolios: this table reports the alpha of the time series regression on the dollar risk factor (DOL) and the carry trade risk factor HML_{FX} of portfolios of currencies sorted according to lagged multivariate tail dependence χ in panel (a), lagged downside countryspecific beta (b). HAC standard errors (s.e.) are reported in parentheses and are obtained by the Newey and West (1987) procedure. Statistical significance has to be interpreted as * $p < 0.10$, ** $p < 0.05$, *** $p < 0.01$. The sample period start on November 27 1992 and ends on December 30 2011, excess returns are daily, annualized and in percentage points. Total number of observations 4810.

	P1	P2	P3	P4	P5
(a) Tail Dependence $\bar{\chi}$					
DOL	1.236*** (0.0197)	1.013*** (0.0207)	1.022*** (0.0208)	1.083*** (0.0211)	1.122*** (0.0253)
HML_{FX}	-0.155*** (0.0168)	-0.0495** (0.0199)	-0.0486** (0.0198)	0.00361 (0.0135)	0.0668*** (0.0224)
α	-0.504 (0.826)	1.327 (0.943)	0.228 (0.990)	-1.173 (0.933)	-1.338 (1.136)
(b) Downside Beta					
DOL	1.135*** (0.0373)	1.009*** (0.0214)	0.914*** (0.0188)	1.086*** (0.0342)	1.277*** (0.0354)
HML_{FX}	-0.291*** (0.0168)	-0.170*** (0.0135)	-0.0264** (0.0130)	0.113*** (0.0183)	0.507*** (0.0354)
α	3.208*** (1.067)	1.490* (0.802)	-0.995 (0.722)	-1.168 (1.019)	-4.365*** (1.574)
N	4810	4810	4810	4810	4810

Table 21: **Robustness I:** this table reports time series regression on the dollar risk factor (DOL) and the carry trade risk factor HML_{FX} . The test assets are monthly excess returns on five currency excess returns portfolios sorted according to the previous day downside-beta. HAC standard errors (s.e.) are reported in parentheses and are obtained by the Newey and West (1987) procedure. Statistical significance has to be interpreted as * $p < 0.10$, ** $p < 0.05$, *** $p < 0.01$. The sample period is 2 January 1986 to 30 December 2011, excess returns are **monthly**. Total number of observations 311.

	P1	P2	P3	P4	P5
DOL	1.201*** (0.0970)	1.005*** (0.0427)	0.870*** (0.0514)	0.969*** (0.0788)	1.200*** (0.0748)
HML	-0.242*** (0.0530)	-0.168*** (0.0377)	-0.0246 (0.0288)	0.0290 (0.0440)	0.470*** (0.0714)
α	0.00247** (0.00125)	0.00153* (0.000793)	-0.000761 (0.000646)	-0.000374 (0.00110)	-0.00376** (0.00163)
N	311	311	311	311	311

Table 22: **Robustness II:** this table reports time series regression on the dollar risk factor (DOL) and the carry trade risk factor HML_{FX} . The test assets are daily excess returns on five currency excess returns portfolios sorted according to the previous day downside-beta with cut-off given by the **mean** equity excess return. HAC standard errors (s.e.) are reported in parentheses and are obtained by the Newey and West (1987) procedure. Statistical significance has to be interpreted as * $p < 0.10$, ** $p < 0.05$, *** $p < 0.01$. The sample period is 2 January 1986 to 30 December 2011, excess returns are daily, annualized and in percentage points. Total number of observations 6558.

	P1	P2	P3	P4	P5
DOL	1.259*** (0.0347)	1.064*** (0.0199)	0.848*** (0.0181)	0.983*** (0.0322)	1.175*** (0.0310)
HML_{FX}	-0.248*** (0.0185)	-0.157*** (0.0140)	-0.00657 (0.0114)	0.0846*** (0.0174)	0.425*** (0.0351)
α	1.686* (0.945)	1.290* (0.693)	-1.210** (0.596)	-0.496 (0.875)	-2.831** (1.355)
N	6558	6558	6558	6558	6558

Table 23: **Robustness III:** this table reports time series regression on the dollar risk factor (DOL) and the carry trade risk factor HML_{FX} . The test assets are daily excess returns on five currency excess returns portfolios sorted according to the previous day downside-beta with cut-off given by the **mean minus half standard deviation** equity excess return. HAC standard errors (s.e.) are reported in parentheses and are obtained by the Newey and West (1987) procedure. Statistical significance has to be interpreted as * $p < 0.10$, ** $p < 0.05$, *** $p < 0.01$. The sample period is 2 January 1986 to 30 December 2011, excess returns are daily, annualized and in percentage points. Total number of observations 6558.

	P1	P2	P3	P4	P5
HML	-0.252*** (0.0185)	-0.145*** (0.0186)	-0.0262*** (0.00982)	0.111*** (0.0188)	0.417*** (0.0362)
DOL	1.255*** (0.0348)	1.097*** (0.0215)	0.827*** (0.0194)	0.993*** (0.0314)	1.163*** (0.0323)
α	1.846* (0.955)	0.630 (0.783)	-0.566 (0.631)	-1.284 (0.915)	-2.241 (1.381)
N	6558	6558	6558	6558	6558

Appendices

B Tail Index and Hill Estimator

Extreme Value Theory (EVT) deals with extreme events and provide theoretical results on the probability distribution in tail regions. The theory provides the limit distribution for the maximum values of a random variable, that is the Generalized Extreme Value Distributions (GEV), and the limit distribution for the tail region, that is the Generalized Pareto Distributions (GPD).

Given a stationary sequence of i.i.d. variables x_1, x_2, \dots, x_n , with a common cumulative distribution F_X , consider the maximum order statistics, defined as

$$M_n = \max(x_1, x_2, \dots, x_n). \quad (68)$$

It can be proved (Fisher-Tippett theorem, see Gnedenko (1943)) that, independently from the distribution of X , $\frac{M_n - a_n}{b_n}$, with a_n and b_n normalizing constants converges asymptotically in distribution to a GEV $G(x)$, i.e.

$$\frac{M_n - a_n}{b_n} \xrightarrow{d} G(x) = \exp\left(-\left(1 + \gamma \frac{(x - \mu)}{\sigma}\right)^{-1/\gamma}\right), \quad (69)$$

or in other words $\Pr\left(\frac{M_n - a_n}{b_n}\right) \xrightarrow{n \rightarrow \infty} G(x)$, where μ , σ and γ are respectively the location, scale and shape parameters. When $\gamma > 0$ the distribution is said to be of Frechet type, has heavy tails, and the number of existing moments of the random variable is equal to the integer value of $\alpha = \frac{1}{\gamma}$ (examples: Student-t, Pareto distribution). If $\gamma = 0$, the distribution belongs to the Gumbel type, has thin tails and an infinite number of moments exist (normal distribution), while if $\gamma < 0$, the distribution has a finite upper limit and has no longer tail (example uniform distribution), and it belongs to the Weibull type, with $\alpha = -\frac{1}{\gamma}$.

In addition to this Beirlant, Vynckier and Teugels (1996) give an important results for events that exceed a certain threshold u , that is events in the tails. Given a continuous distribution function $F_X(x)$ and a threshold u smaller than the right end-point of X , the

distribution of X about the threshold converges to a generalized Pareto distribution (GDP) (with only one parameter), that is

$$F_X^u(x) = \Pr(X \leq z | X > u) \sim 1 - (1 + \gamma x)^{-\frac{1}{\gamma}}. \quad (70)$$

It collapse to $F_X^u(x) = 1 - x^{-\alpha}$ ($x \geq 1$) for the Frechet type limit, $F_X^u(x) = 1 - (-x^\alpha)$ ($0 \geq x \geq 1$) for the Weibull and $F_X^u(x) = 1 - \exp(-x)$ ($x \geq 0$) for the Gumbel.

Therefore, given the previous two results, EVT can describe the behavior of large observations, independently from the distribution of the fluctuations of the overall system, and provides also the functional form for the description of the tails.

Extreme events of return series and many other processes have been empirically shown to be governed by Pareto or power law (see Gabaix, Parameswaran, Plerou and Stanley (2003)). EVT provides theoretical roots to these evidences, as Pareto distributions are the limit of large events for a whole class of probability distribution, as just shown.

Most commonly in the literature a process X is said to have a power law tail if

$$\Pr(X \geq x) \sim x^{-\alpha}, \quad \text{for } x \neq u \quad (71)$$

where $\alpha = 1/\gamma$ is called the “tail index”.

In the paper we estimate α by means of a non-parametric estimator introduced by Hill (1975). This estimator is asymptotically unbiased and it is the most efficient among all the others proposed:

$$\hat{\alpha} = \left(\frac{1}{k} \sum_{i=1}^k \left[\log \left(\frac{X_{(n+1-i)}}{u} \right) \right] \right)^{-1}, \quad (72)$$

where k is the number of observations above the threshold u , n is the total sample size and $X_{(i)}$ denotes the ordered statistics, i.e. $X_{(1)} \leq X_{(2)} \leq \dots \leq X_{(n)}$. Of course the choice of the threshold u is crucial, as too many observations can bias the estimate, while too few can enlarge its variance. Among the several method introduced for jointly estimating α and u we adopt the one of Clauset, Shalizi and Newman (2009). We refer to their article for details.